



**USAID**  
FROM THE AMERICAN PEOPLE

## ADS Chapter 220

# Strengthening the Capacity of Partner Governments through Government-to-Government (G2G) Assistance

Full Revision Date: 01/13/2021  
Responsible Office: M/CFO and PPL  
File Name: 220\_011321

Functional Series 200 – Programming Policy  
 ADS 220 – Strengthening the Capacity of Partner Governments through  
 Government-to-Government (G2G) Assistance  
 POCs for ADS 220: Grace Yang, (202) 712-4360, [gyang@usaid.gov](mailto:gyang@usaid.gov); Walter  
 Hammond, (202) 916-4136, [whammond@usaid.gov](mailto:whammond@usaid.gov)

## Table of Contents

<a href="#"><u>220.1</u></a>	<a href="#"><u>OVERVIEW .....</u></a>	<a href="#"><u>3</u></a>
<a href="#"><u>220.2</u></a>	<a href="#"><u>PRIMARY RESPONSIBILITIES .....</u></a>	<a href="#"><u>4</u></a>
<a href="#"><u>220.3</u></a>	<a href="#"><u>POLICY DIRECTIVES AND REQUIRED PROCEDURES .....</u></a>	<a href="#"><u>7</u></a>
<a href="#"><u>220.3.1</u></a>	<a href="#"><u>Relation of This Chapter to Other Agency Guidance .....</u></a>	<a href="#"><u>9</u></a>
<a href="#"><u>220.3.2</u></a>	<a href="#"><u>Applicability of Guidance for Using a Partner Government's Systems and Institutions .....</u></a>	<a href="#"><u>10</u></a>
<a href="#"><u>220.3.3</u></a>	<a href="#"><u>Eligibility of Partner Governments for G2G Assistance .....</u></a>	<a href="#"><u>14</u></a>
<a href="#"><u>220.3.3.1</u></a>	<a href="#"><u>Eligibility Criteria and Determination .....</u></a>	<a href="#"><u>15</u></a>
<a href="#"><u>220.3.4</u></a>	<a href="#"><u>Planning and Designing for the Use of a Partner Government's Systems and Institutions .....</u></a>	<a href="#"><u>17</u></a>
<a href="#"><u>220.3.4.1</u></a>	<a href="#"><u>Overview of Risk Management Approach.....</u></a>	<a href="#"><u>18</u></a>
<a href="#"><u>220.3.4.2</u></a>	<a href="#"><u>Phase 1: Planning for Use of a Partner Government's Systems and Institutions.....</u></a>	<a href="#"><u>21</u></a>
<a href="#"><u>220.3.4.3</u></a>	<a href="#"><u>Approval of the Planning and Parameters of a G2G Activity.....</u></a>	<a href="#"><u>23</u></a>
<a href="#"><u>220.3.4.4</u></a>	<a href="#"><u>Phase 2: Steps and Requirements in the Design Process.....</u></a>	<a href="#"><u>24</u></a>
<a href="#"><u>220.3.4.5</u></a>	<a href="#"><u>Analysis and Requirements for Designing and Managing the Risk of a G2G Activity .....</u></a>	<a href="#"><u>25</u></a>
<a href="#"><u>220.3.4.6</u></a>	<a href="#"><u>Defining the Scope and Implementing Mechanism for the G2G Activity ..</u></a>	<a href="#"><u>31</u></a>
<a href="#"><u>220.3.4.7</u></a>	<a href="#"><u>Approval of a G2G Activity and the Use of a Partner Government's Systems and Institutions .....</u></a>	<a href="#"><u>33</u></a>
<a href="#"><u>220.3.5</u></a>	<a href="#"><u>Types of Partner Government Implementing Mechanisms .....</u></a>	<a href="#"><u>35</u></a>
<a href="#"><u>220.3.6</u></a>	<a href="#"><u>Implementing through a Partner Government's Systems and Institutions .....</u></a>	<a href="#"><u>42</u></a>
<a href="#"><u>220.3.6.1</u></a>	<a href="#"><u>Role and Designation of the Government Agreement Technical Representative (GATR) .....</u></a>	<a href="#"><u>44</u></a>
<a href="#"><u>220.3.6.2</u></a>	<a href="#"><u>Planning for Monitoring, Evaluation, and CLA .....</u></a>	<a href="#"><u>46</u></a>
<a href="#"><u>220.3.6.3</u></a>	<a href="#"><u>Monitoring, Evaluation, and CLA During Implementation of a G2G Agreement .....</u></a>	<a href="#"><u>48</u></a>
<a href="#"><u>220.3.6.4</u></a>	<a href="#"><u>Managing the G2G Agreement and the Relationship with the Partner Government .....</u></a>	<a href="#"><u>53</u></a>

<u>220.3.7</u>	<u>Closing Out a G2G Activity .....</u>	<u>56</u>
<u>220.4</u>	<u>MANDATORY REFERENCES .....</u>	<u>58</u>
<u>220.4.1</u>	<u>External Mandatory References .....</u>	<u>58</u>
<u>220.4.2</u>	<u>Internal Mandatory References .....</u>	<u>59</u>
<u>220.5</u>	<u>ADDITIONAL HELP .....</u>	<u>60</u>
<u>220.6</u>	<u>DEFINITIONS .....</u>	<u>61</u>

## 220.1 OVERVIEW

Effective Date: 01/13/2021

The vision of the [Journey to Self-Reliance](#) in the development policy of the U.S. Agency for International Development (USAID) includes the Agency's commitment to support partner governments in planning, financing, and implementing solutions to local development challenges. To this end, USAID seeks to strengthen our relationships with partner governments and transition our engagement from traditional donor-recipient roles to an increased emphasis on investing foreign assistance in a manner that recognizes the role of the government in a country's development and decreases—or eliminates—the need for foreign assistance in the future. But investing through partner governments is not an end in itself; such financial relationships must advance measurable development goals, increase the capacity of national and local systems and institutions, and bring us closer to the end of the need for foreign assistance.

The concept of promoting national self-reliance is fundamental to the design and implementation of USAID's programs. Aid-effectiveness relates to measures that improve the quality of the aid relationship, primarily focused on the terms and conditions of the transfer of resources itself. External aid investments are most likely to catalyze sustained development processes when they reinforce a country's internally determined development priorities (country ownership) and arrangements (national and local institutions and networks). Inclusive country ownership means that USAID and our partners establish development priorities that are broadly responsive to citizens' needs and aspirations. Inclusive country networks recognize that all parts of society—certainly the government, but also civil society, faith-based organizations, the private sector, universities, and individual citizens—have important resources, ideas, and energy that are essential for the Journey to Self-Reliance (see the [Paris Declaration on Aid Effectiveness](#) and the [Busan Partnership for Effective Development Cooperation](#)). A development partnership with a partner government means the following:

- **Country Ownership** – Partner governments should define the development model they want to implement, based on input from their citizens. USAID works with national (and, sometimes, sub-national) governments to implement an activity based on mutually agreed objectives. Government-to-Government (G2G) agreements are a result of a process of co-creation and co-design, which requires negotiation and trust (see [Discussion Note: Co-Creation in the Program Cycle](#)). The agreements should address and seek to mitigate the risk of personal and organizational conflict of interest and the disclosure of non-public information (appropriate models include mitigation plans and non-disclosure agreements used by Contracting Officers (COs) in the context of U.S. Government contracts).
- **Partnership** – USAID's foreign assistance should go beyond a donor-grantee relationship. G2G agreements provide a mechanism to redefine this relationship into one of real partners and peers, which requires shared decision-making and accountability. Such partnerships depend upon dialogue and negotiation around

the objectives of G2G assistance and the strengthening of government systems and institutions for sustaining such objectives, rather than inadvertently contributing to fragmenting systems and institutions, or creating parallel ones.

- Capacity Development – By investing foreign assistance carefully through a partner government’s systems and institutions, USAID can provide tailored support to fit country-specific needs that respond to public-sector solutions.

Along with other donors, the U.S. Government (USG) has committed to the use of national and sub-national systems and institutions as the default approach for cooperation in support of activities managed by the public sector. G2G assistance uses a partner government’s systems and institutions to deliver assistance where the operating environment permits, and sufficient commitment and capacity exists, or USAID could strengthen them. G2G assistance is one of the programmatic tools USAID uses to ensure better performance, sustainability, and self-reliance, consistent with [ADS Chapter 201, Operational Policy for the Program Cycle](#).

USAID’s staff must understand the operating context and the inherent risks and opportunities associated with local systems and institutions, including public-sector ones, when designing and implementing development assistance. To further this concept, USAID developed [Local Systems: A Framework for Supporting Sustained Development](#). To assist staff in understanding and being prepared to address these risks and opportunities, including those associated with G2G assistance, USAID developed a [Risk Appetite Statement \(RAS\)](#), as part of our [Enterprise Risk-Management \(ERM\)](#) program. Under ERM, the Agency emphasizes risk management that goes beyond fiduciary and reputational risk to include programmatic, security, legal, human capital, and information technology risks, to optimize the Agency’s overall performance and strategic decision-making.

This chapter integrates the [Local Systems Framework](#), the Agency’s ERM approach, and the components of our Program Cycle in streamlined processes that encourage the appropriate use of partner governments’ systems and institutions to deliver assistance (see [ADS 220sak, Writing Framework](#)). This chapter describes the processes and procedures that apply to USAID’s Operating Units (OUs) as they plan, design, and implement activities with partner governments as implementing partners and through national and sub-national systems and institutions.

## **220.2 PRIMARY RESPONSIBILITIES**

Effective Date: 01/13/2021

[ADS 201.3.4.1](#) describes the roles and responsibilities in the design and implementation of activities. Activities implemented through use of a partner government’s systems or institutions require additional, specific responsibilities for a wide range of stakeholders. The following have specific roles in planning, designing, and implementing G2G activities, and in forging a real, peer-to-peer relationship with partner governments.

- a.** The **Mission Directors/Principal Officers**, in coordination with the cognizant U.S. Chief of Mission, often serve as the designated USG representative that will direct the establishment of a Partner Government System Team (PGST) and lead and promote collaboration and mutual accountability between USAID and the partner government. Mission Directors/Principal Officers have the authority to sign agreements with partner governments in implementing foreign assistance and should issue Mission Orders, as needed, to assign the functional responsibilities for agreements with partner governments. In consultation with the Director(s) of the relevant Technical Office(s) at the Mission, the Mission Director designates a Government Agreement Technical Representative (GATR) to manage G2G awards on a day-to-day basis.
- b.** The **Mission Program Office** provides oversight of a Mission’s design and implementation of activities and ensures each G2G investment appropriately balances sector-specific technical objectives and broader goals, such as increasing government capacity and fostering self-reliance and national ownership of development projects. The Program Office has a key role in planning and designing each G2G activity to ensure the approval processes incorporate and satisfy relevant policy requirements and guides the relevant technical team(s) during implementation on review and reporting requirements.
- c.** The **Mission Resident Legal Officers (RLOs)** provide legal counsel and advice on a broad range of matters related to the planning, design, negotiation, and implementation of G2G agreements and activities. In addition to ensuring compliance with relevant policies and statutes, RLOs have a specific role in the process of negotiating accords with partner governments and other development actors and documenting those in the final agreement.
- d.** The **Mission Technical Offices** (*i.e.*, Health, Education, Economic Growth, etc.) serve as the lead for the Mission in determining if G2G is appropriate for the development objectives and will support the Mission’s goals under its Country Development Cooperation Strategy (CDCS) or Regional Development Cooperation Strategy (RDCS). The Technical Offices will work to lead aspects of the risk assessments that review technical and management risks and develop and monitor risk mitigation measures. A Mission Director often will designate a technical officer as the GATR, as outlined in section **220.3.6.1**. The technical teams will work closely with other members of the PGST to monitor technical performance and reporting requirements, as well as review financial aspects of the award. The Director of each Technical Office responsible for a G2G agreement will nominate a GATR and alternate. The Mission Director must approve these designations.
- e.** The **Mission Office for Democracy and Governance (DG)**, in coordination with the Bureau for Development, Democracy, and Innovation (DDI), Center of Excellence on Democracy, Human Rights, and Governance (DRG), assesses the adequacy of each partner country’s democracy, human rights, and governance environment to engage in G2G, and identifies any problems with citizen-responsive, democratic accountability that an activity that includes G2G funding agreements may have to address.

**f.** The **Mission’s Financial Management Office (OFM)** identifies, analyzes, and develops alternatives for addressing risks within the G2G risk management process, as well as documents and monitors progress on selected mitigation measures. OFM serves as a key office on all financial aspects of G2G risk assessment and provides monitoring and oversight on the proper financial reporting and accounting treatment during the implementation of G2G activities, to ensure the partner government meets the financial reporting terms of the relevant G2G agreement, and that financial transactions between USAID and the partner government conform to both the specific terms of that agreement and USAID’s policy. OFM also supports audit and financial-review engagements related to G2G agreements.

**g.** The **Mission Executive Office (EXO)** provides expertise in understanding host-country regulations, systems, and institutions related to human resources and the civil service. The EXO ensures that sufficient human-capital resources exist within a Mission to carry out the roles and responsibilities required under a G2G agreement.

**h.** The **Mission Office of Acquisition and Assistance (OAA)** supports GATRs to oversee and administer G2G agreements. OAA provides expertise in understanding and evaluating the public procurement systems and institutions in our partner countries and may provide guidance on capacity development activities that strengthen them; assistance and expertise on estimating costs, negotiating, and drafting G2G agreements; and guidance on the use of fixed-amount reimbursable activities and host-country contracts.

**i.** Other **Cross-Cutting Advisors and Points of Contact (POCs)** in a Mission may include a Mission Engineer, a Mission Economist, an Advisor for gender or marginalized populations, and/or others. Advisors/POCs conduct, facilitate, and review analyses to provide insight about technical issues related to their respective areas of responsibility; and provide advice, guidance, and follow-up on respective issues in the design and implementation of activities.

**j.** **USAID’s Washington OUs/Regional Missions** provide guidance to our Missions on policies and priorities; support them with technical expertise through the Agency Approach to Field Services (AAFS); ensure the implementation of Agency-wide sector strategies and initiatives; and provide field support, as requested, to Missions in support of the functions outlined in this section, including for analyses and the collection of other evidence needed to develop activity designs. The following are USAID’s Washington OUs/Regional Missions with specific roles in the provision of G2G assistance:

- 1) The **Bureau for Policy, Planning, and Learning (PPL)** sets the Agency’s development policy, including the use of government systems and institutions and G2G agreements to achieve development objectives and integrate G2G partnerships into USAID’s Program Cycle. As needed, PPL interprets the language in these policies in collaboration with the Office of the General Counsel (GC).

- 2) The **Agency's Chief Financial Officer (CFO)** leads the **Bureau for Management, Office of the Chief Financial Officer (M/CFO)** and serves as the Agency's ERM Secretariat overseeing the Risk Management Team (RMT). M/CFO provides policy, guidance, technical assistance, and training on G2G activities, and supports Missions and Controllers in the application of the G2G risk management process.
  - 3) **DDI/DRG** makes recommendations on a country's performance for DRG-related indicators under the process required by Section 7031(a) of the annual Department of State, Foreign Operations, and Related Programs Appropriations Act (SFOAA), as amended (see section **220.3.3.1**) and develops guidance and methodology for the Expanded DRG Review, as warranted by country-level performance. DDI/DRG may assist a Mission in adapting the design of a G2G activity based on the conclusions of the G2G Risk Management Process and/or Expanded DRG Review.
  - 4) The **Office of Budget and Resource Management (BRM)** is responsible for USAID's resource-planning processes and budget capabilities that prioritize investments, informed by policy priorities and anticipated impacts. With the U.S. Department of State's, Bureau for Foreign Assistance (State/F), BRM coordinates the list of countries eligible for G2G agreements under 7031(a) of the SFOAA, as amended, consistent with the specific appropriations accounts and Congressional directives.
  - 5) **Regional and Technical Bureaus and Offices** assist USAID's Missions and PGSTs in designing and reporting on G2G agreements and activities, as well as coordinating G2G best practices and technical approaches between and among Missions. Assistant Administrators (AAs) of Regional Bureaus consult, as requested, with their respective Mission Directors/Principal Officers concerning difficult or politically sensitive operating environments, determine whether concerns in the country context require additional review, or assist a Mission in choosing whether or not to invoke a waiver. They also direct and mobilize Bureau resources and assist Missions, as necessary.
- k. The **U.S. Department of State's, Bureau for Foreign Assistance (State/F)** coordinates country-wide reviews against the criteria specific to G2G programming in section 7031(a) of the SFOAA, as amended, jointly conducted with BRM and USAID's Regional Bureaus (see section **220.4.1** for more details).

## 220.3 POLICY DIRECTIVES AND REQUIRED PROCEDURES

Effective Date: 01/13/2021

### 1. Approach

This chapter provides guidance on how USAID carries out [Redefining our Relationship with Partner Governments](#) (RDR) as part of our vision for the Journey to



Self-Reliance. USAID's engagement through G2G assistance is one of the foremost expressions of redefining the development relationship with partner governments, given the partnership nature of the relationship, which shares decision-making and accountability while supporting both a Journey to Self-Reliance and U.S. foreign-policy objectives, in the way we design and implement G2G assistance. Long-term, sustainable development outcomes depend on the ability of partner governments' agencies to perform their defined roles. These are definitions of key terms used in this chapter:

- **Strengthening:** Increasing the capacities of local actors—governments, civil society, and private sector—and national systems and institutions. USAID's investments can accomplish this strengthening through a variety of means, including direct assistance to partner governments.
- **Use:** Relying on national and local systems and institutions to produce desired outcomes. Direct assistance to partner governments is an essential feature of using these systems and institutions.

Since fostering self-reliance is our objective, USAID is committed to employing our development resources to strengthen and use national and local systems and institutions.

This ADS chapter provides strategic and design guidance on how USAID's OUs can provide direct assistance to partner governments to use or strengthen their internal systems and institutions. Topics include the following:

- The eligibility of partner governments (see section **220.3.3**);
- The risks associated with providing funds to sovereign states to implement activities through their systems and institutions;
- The Agency's [risk management](#) approach and tolerance of the risks associated with the delivery of assistance; and
- Policies and procedures for addressing these special concerns when considering the use of a partner government's systems and institutions in implementing foreign assistance.

The [G2G Process Mapping](#) provides a summary of the entire G2G planning, design, and implementation process, and [ADS 220mak, Process and Documentation Requirements for G2G Assistance](#) provides a summary of the required documentation.

## 2. Policies and Procedures

The use of G2G assistance can foster local ownership and promote sustainable development results beyond USAID's funding. A Mission's decision to use G2G agreements will result from strategic planning, from the design of projects and/or activities to identify and achieve a clearly stated development outcome, and from risk assessment and risk mitigation processes that consider the best means to invest American taxpayer resources.

This chapter includes built-in flexibility to meet the varying needs and experiences of USAID's Missions. For example, those with G2G experience may require no more than several months to plan, design, and begin implementing a G2G activity, while others may require additional time to design and initiate a G2G agreement appropriate for their country context.

Missions should determine the desired development results and how best to engage local partners--including the decision of whether to use G2G mechanisms--as part of the country-level processes outlined in [ADS 201](#) for strategic planning and designing projects and activities (see [ADS 201.3.4.3, Incorporating Self-Reliance into Project \(and Activity\) Design](#) for more information). Similar to [ADS 201](#), the use of these policies and procedures also imply rethinking the roles of a portion of Mission staff, beyond the management of contracts, grants, and cooperative agreements. This includes promoting policy reforms and dialogue, facilitation, technical interaction, mentoring and capacity development of local organizations and new and underutilized partners, and carrying out advisory services, which may require upgrading the skills of our staff (see sections [220.3.5.1](#), [220.3.4.2.B](#), and [220.3.5.2.B](#)).

This chapter complements [ADS 201](#) by describing the specific requirements and procedures that apply to designing and implementing G2G programming. These include the risk management process, practices and tools that apply to G2G assistance and the mechanisms available for financing and monitoring it, and potential capacity-development associated with G2G assistance.

For guidance on waiving any requirements of this chapter, see section [220.3.2](#). USAID's OUs are not required to document deviations from non-mandatory procedures; however, they should do so for the purposes of Agency-wide learning, providing clarification for audit purposes, and to ensure continuity during staff transitions. In this chapter: "must" denotes the imperative and indicates a mandatory policy or procedure; "should" or "may" indicate a non-mandatory, but recommended, policy, procedure, or course of action.

### **220.3.1 Relation of This Chapter to Other Agency Guidance**

Effective Date: 01/13/2021

This ADS chapter supplements, but does not replace, existing USAID policy and guidance in:

- [ADS 201, Operational Policy for the Program Cycle](#). The Program Cycle is USAID's operational model for planning, designing, monitoring, evaluating, and

Collaborating, Learning and Adapting (CLA) processes for development programming in a given region or country to advance U.S. foreign policy. OUs should use **ADS 220** in conjunction with [ADS 201](#) when providing guidance on processes and procedures that apply to agreements with partner governments. Where applicable, these agreements should fit within the context of achieving the Development Objectives and associated Results Frameworks of a CDCS or RDCS, and any associated projects, if applicable.

- [ADS 308, Agreements with Public International Organizations](#). This chapter provides the policy and procedures for entering joint funding arrangements and other coordination measures with a Public International Organization (PIO), including for the purpose of implementing assistance that strengthens a partner government's systems and institutions.
- [ADS 350, Grants to Foreign Governments](#). This chapter describes the policies and procedures for grants to foreign governments, including Development Objective Agreements (DOAGs). Cost reimbursement and fixed amount reimbursement (FARA) G2G agreements often take the form of implementing letters under DOAGs or similar grant agreements with partner governments.
- [ADS 351, Agreements with Bilateral Donors](#). This chapter provides the policy and procedures for entering into a funding agreement with another donor, including for the purpose of implementing assistance that strengthens a partner government's systems and institutions, while **ADS 220** provides guidance on how to identify opportunities to strengthen these systems and institutions through such arrangements.
- [ADS 591, Financial Audits of USAID Contractors, Recipients, and Host Government Entities](#). This chapter provides the policy directives and required procedures for planning and conducting financial audits of USAID-funded contractors and recipients, including host-government entities. The risk management processes described in **ADS 220** follow a holistic approach, as described in [USAID's Risk Appetite Statement](#) and the [Technical Note: Enterprise Risk Management in the Program Cycle](#). They also fulfill the pre-financing due-diligence requirements ("pre-award audits") described in [ADS 591](#) for G2G activities. No separate pre-financing, audit-like, or due-diligence assessments, other than described in this ADS chapter, are required for USAID's financing of G2G projects and activities.
- [ADS 624, Host-Country-Owned Foreign Currency](#). This chapter outlines the financial management policies governing host country-owned foreign currency related to G2G program assistance agreements such as non-project sector assistance programs, cash transfers, and Food for Peace Programs.

### **220.3.2 Applicability of Guidance for Using a Partner Government's Systems and Institutions**

Effective Date: 01/13/2021

## I. Applicability

This chapter applies to all USAID OUs that consider using a partner government's systems and institutions as a method to implement their activities, or which include strengthening and streamlining these government systems and institutions as part of the Mission's overall strategy and Theory of Change (TOC). OUs must ensure that partner governments meet the eligibility criteria in section **220.3.3.1** prior to following the other processes and procedures outlined in this chapter. This chapter applies to agreements for which USAID will disburse funds directly to a partner government implementing entity as defined below and in section **220.6**.

- 1) A Partner Government Implementing Entity. For purposes of this chapter, a partner government implementing entity is an office, organization, or body at any level of a public administration system (ministry, department, agency, service, district, or municipality) that implements activities financed or jointly programmed as a result of funds disbursed by USAID directly to a partner government's public financial management system. Partner government implementing entities include parastatals and quasi-governmental entities, including universities, as follows:
  - a. Parastatals and quasi-governmental entities formed primarily for commercial purposes are not partner government implementing entities, and generally are not subject to this ADS chapter. Instead, agreements with these institutions must follow either [ADS 302, USAID Direct Contracting](#), or [ADS 303, Grants and Cooperative Agreements to Non-Governmental Organizations](#), as applicable, including the requirements in these chapters for responsibility determinations/pre-award surveys.
  - b. Non-commercial government parastatals and quasi-governmental organizations, including universities, qualify as a partner government implementing entity and require compliance by the financing OU when they meet the following five criteria:
    1. A majority of the organization's supreme governing body is comprised of government officials;
    2. The entity delivers public goods or services;
    3. The entity is subject to audit by the partner government's supreme audit institution;
    4. The entity uses the partner government's public financial management (PFM) and procurement systems; and

5. Implementation will involve the use of the partner government's PFM or other systems and institutions.

However, OUs may decide, at their discretion, to apply certain processes from this chapter, such as carrying out a risk assessment even when parastatals or quasi-governmental organizations do not meet all of the five criteria listed above, when the Mission Director/Principal Officer determines that application of **ADS 220** to a parastatal or quasi-governmental organization is in the best interest of the USG or USAID. The OU must document this determination.

- 2) Grants under Contract (GUC), Contracts, and Sub-Awards. The eligibility and risk assessment requirements in sections **220.3.3**, **220.3.3.1**, and **220.3.4.1** also apply to GUCs that provide funds to a partner government implementing entity (see [ADS 201](#), [ADS 302](#), and section **220.3.4.3**). These requirements do not apply to contracts or sub-contracts with a partner government implementing entity awarded pursuant to [ADS 302](#), or to assistance sub-awards to a partner government's implementing entity made by recipients pursuant to [ADS 303](#).
- 3) "Program Assistance" or "Non-Project Assistance." The eligibility and risk assessment requirements in sections **220.3.3**, **220.3.3.1**, and **220.3.4.1** also apply to "Program Assistance" or "Non-Project Assistance" agreements (see [ADS 624](#) for additional information on how program assistance may generate financial management requirements specific to the host country-owned local currency).
- 4) PIOs and Bilateral Donors. For assistance to partner governments that use a PIO agreement or agreement with another donor for project approaches, joint funding arrangements, and other coordination measures, the policy requirements in sections **220.3.3**, **220.3.3.1**, and **220.3.4.1** do not apply. [ADS 308](#) and [ADS 351](#), respectively, provide the policy and procedures for entering into funding agreements for such purposes. For example, when working with a PIO that is serving as the Trustee of a Multi-Donor Trust Fund or the lead of a pooled funding arrangement through which USAID and other donors' funds flow through a partner government's systems and institutions, the OU must follow [ADS 308.3.2\(2\)](#).

## II. Minimum Legal Requirements

Unless relying on statutory "notwithstanding" authority (see section **220.3.2**), before authorizing an activity and subsequently obligating or sub-obligating funds to disburse directly to a partner government, OUs must follow section **220.3.4.1** to:

- 1) Assess the partner government's implementing entity and all PGSTs to use in connection with the proposed assistance, including the degree to which the partner government's implementing entity:

- a. Employs and uses staff with necessary technical, financial, and management capabilities;
  - b. Has adopted competitive procurement policies and systems; and
  - c. Puts effective systems for monitoring and evaluation in place to ensure that USAID's assistance is used for its intended purposes.
- 2) Determine and document that a partner government's implementing entity or ministry has the systems required to manage the proposed assistance.
- 3) Address any identified vulnerabilities or weaknesses.

These represent the minimum legal G2G risk assessment requirements for USAID assistance that Missions may not waive. The G2G risk management process, together with other requirements of the activity-design process, is the primary way to fulfill this statutory requirement.

### **III. Waiver of Policy Requirements Based on Impairment of Foreign Assistance Objectives**

To waive certain elements of the G2G risk management process or any other policy requirement in this ADS chapter that is not legally required, the OU must document that compliance with the policy requirement will impair USAID's ability to achieve its foreign-assistance objectives.

Before considering a waiver, the OU should note that many aspects of G2G risk management and due-diligence policies and procedures are flexible and customizable for country- and activity-specific contexts, as well as tailored to the types of agreements used for G2G. In addition, before invoking a policy waiver, Missions must liaise with Washington support offices, including M/CFO and DDI/DRG, regarding the proposed waiver.

- 1) Missions may request, via an Action Memorandum which the AA of the relevant Regional Bureau must approve, a waiver of the policy based G2G requirements and procedures of this ADS chapter to avoid impairment of foreign assistance objectives. In this case, the OU must develop an Action Memorandum, with M/CFO, DDI/DRG, and the relevant Technical Bureau copied, to document:
- a. The technical justification for the waiver to deviate from the mandatory requirements of this chapter;
  - b. The results of any consultations with M/CFO, DDI/DRG, and the relevant Technical Bureau;
  - c. Relevant U.S. foreign policy considerations and their potential impairment, including the USG's relationship and experience with the partner

government, and USAID’s relationship and experience with the partner government’s implementing entity or entities;

- d. The value of the G2G activities being contemplated (the technical results and the financial risk exposure); and
  - e. Relevant factors concerning the country’s current overall development performance, based on the indicators for Capacity and Commitment in our Journey to Self-Reliance [Country Roadmaps](#).
- 2) If the cognizant AA approves a waiver pursuant to this section, “Waiver of Policy Requirements Based on Impairment of Foreign Assistance Objectives”, the Mission must still undertake and document the requirements in [ADS 220mak, Process and Documentation Requirements for G2G Assistance](#) for activities that rely on this waiver.

#### IV. Reliance on Notwithstanding Authority

For G2G assistance financed with funds that include “notwithstanding authority,” a Mission may forego the legal requirements of this ADS chapter (see [ADS 220mac, Pre-Obligation Requirements for Government-to-Government \(G2G\) Assistance](#)), including those above, after formal consultation with the AA of the cognizant Regional Bureau and the RLO or GC attorney, as well as the G2G Risk Management Team in M/CFO for requirements related to risk management. Documentation of the following is required in [ADS 220mal, G2G Activity Planning Approval Memorandum \(APAM\)](#):

- a. Such consultations;
- b. The specific statutory requirement being waived; and
- c. The “notwithstanding” authority.

#### **220.3.3 Eligibility of Partner Governments for G2G Assistance**

Effective Date: 01/13/2021

This section describes threshold eligibility criteria and the process required to ensure eligibility prior to entering into an agreement with a partner government in implementation of G2G assistance (see Fig. 1 for a decision tree on the eligibility process).

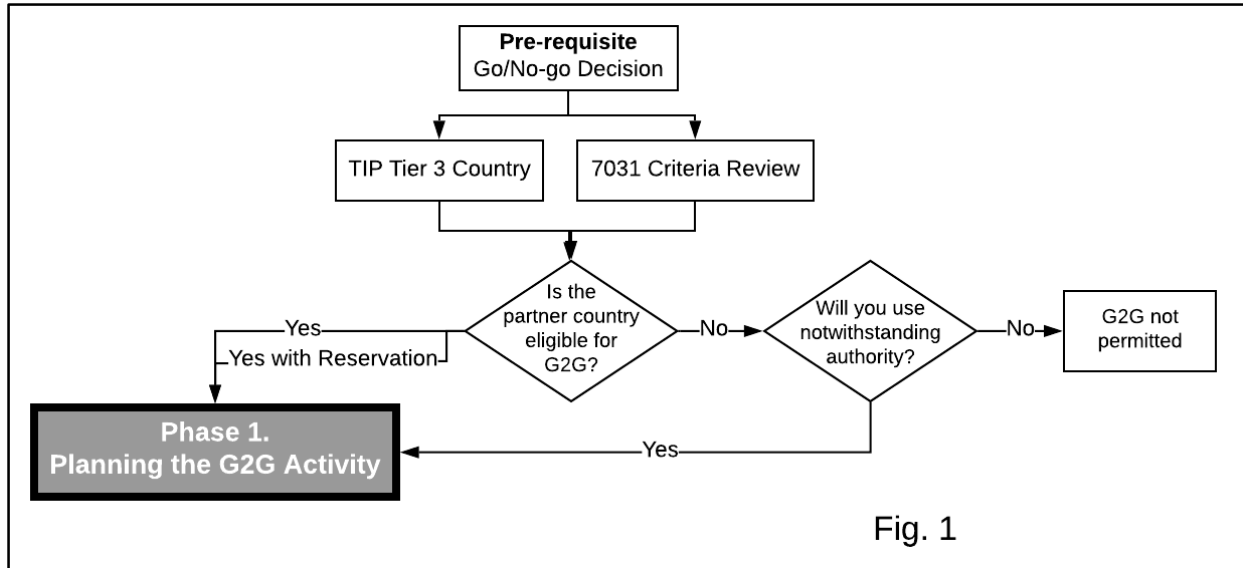

Fig. 1

**220.3.3.1 Eligibility Criteria and Determination**  
 Effective Date: 01/13/2021

G2G assistance is only legally available as a modality when the partner government implementing entity meets certain criteria, which USAID must include in a Congressional Notification. Such funding is often subject to certain additional Congressional reporting requirements. When an OU begins to consider G2G assistance, it must first verify that USAID and the Department of State has deemed a country to meet the following requirements (see Figure 2).

**1. Review under section 7031(a) of the Annual Department of State Foreign Operations and Related Programs Appropriations Act (SFOAA)<sup>1</sup>**

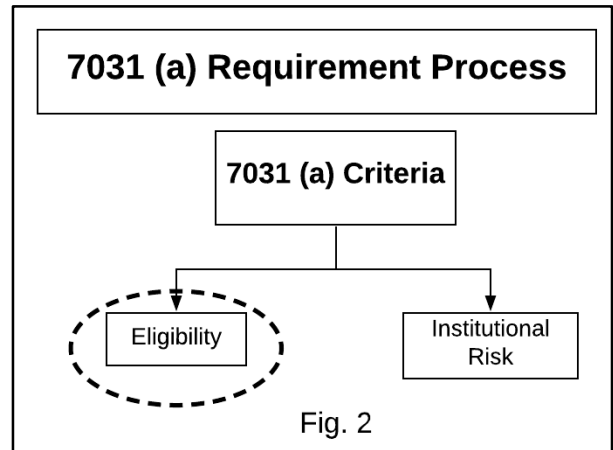

Fig. 2

In addition to the minimum requirements for partner government implementing entities laid out in section 220.3.2, [Section 7031\(a\)](#) of the annual SFOAA also requires a partner government as a whole (rather than just the implementing entity) to meet certain criteria related to accountability to be eligible for G2G assistance. State/F carries out a review of these criteria in consultation with USAID. A Mission must initiate a request to the leadership of its Regional Bureau to use national systems and institutions in

<sup>1</sup>Section 7031(a) of the annual SFOAA requires that partner governments meet eligibility criteria and go through institutional risk assessments that determine the use of partner government systems and institutions for implementation of G2G assistance. Section 220.3.3.1 covers the eligibility criteria, while section 220.3.4.5 covers the institutional risk.



implementation of G2G assistance. The Regional Bureaus will coordinate with BRM, DRG, and PPL to choose Missions to evaluate eligibility in the relevant Fiscal Year. The review assesses partner governments against the following statutory requirements:

- a. The government of the recipient country is taking steps to disclose its national budget publicly on an annual basis, to include income and expenditures;
- b. The recipient government is taking steps to protect the rights of civil society, including the freedoms of expression, association, and assembly; and
- c. The recipient government follows the principles of the legal prohibition on taxation of U.S. foreign assistance.

### **Determination of Eligibility under Section 7031(a) of the SFOAA**

State/F provides final documentation of the assessment of a partner government's eligibility, after review by multiple offices in USAID and the Department of State (hereinafter, "State") and final determinations made by State and USAID.

Determinations regarding requests from USAID's Regional Bureaus rely on the recommendation of DDI/DRG for the requirements above, as well as information from the relevant OUs on all three requirements. State/F documents the determination in a memorandum that lists all the countries whose governments are eligible for G2G assistance (available in the [G2G Resource Library](#)). DDI/DRG bases its recommendations on a review of objective indicators and available information at the country level, and uses the following ratings to make recommendations to BRM, PPL, and USAID's Regional Bureaus:

- 1) **Pass** - The country clearly meets or exceeds the designated criteria. Those countries that receive a "passing" rating on the review under Section 7031(a) of the SFOAA will appear on the list of countries recommended as eligible for G2G assistance.
  - 2) **Pass with Reservation** - The performance of the country is ambiguous and needs further assessment. Countries that receive a "pass with reservations" rating will appear on the list of countries recommended for G2G assistance but have to undergo an expanded review by DDI/DRG as a part of their G2G risk management process to deepen the analysis and provide additional considerations and mitigation measures that would allow the country to proceed favorably in the review.
  - 3) **Fail** - The country clearly fails one or both criteria related to democracy and governance, and DDI/DRG will not recommend it.
2. **Ranking on the Annual [Trafficking in Persons \(TIP\) Report](#) Published by the Department of State**

The annual [TIP Report](#) classifies countries in tiers based on their governments' efforts to comply with the minimum standards for the elimination of trafficking as defined in the [2000 U.S. Trafficking Victims Protection Act \(TVPA\)](#). Tier 1 includes countries that are meeting the minimum standards. Tier 2 includes countries that do not comply fully with the TVPA's minimum standards but are making significant efforts to do so. Tier 3 comprises countries that are neither fully complying with the minimum standards nor making significant efforts to do so. A Tier 2 Watch List comprises countries that require special scrutiny in the coming year, including those with a significant or increasing number of TIP victims or that fail to provide evidence of increased efforts at combating severe forms of trafficking from the previous year. Countries may remain on the Tier 2 Watch List for a maximum of three consecutive years before moving automatically to Tier 3.

If a country falls into Tier 3, the national government is subject to the TVPA's restrictions on non-humanitarian, non-trade related assistance from the U.S. Government. These sanctions cover G2G assistance and could include funding for the participation by officials or employees of such governments in educational and cultural exchange programs and other types of activities that constitute assistance to such governments.

The annual State/USAID TVPA exercise reviews the list of Tier 3 countries in the TIP Report and makes recommendations for Presidential waivers for assistance to, or for the benefit of, the governments of these countries. For those countries not granted waivers in the Presidential Determination ([Presidential Memorandum on Determination with Respect to the Efforts of Foreign Governments Regarding Trafficking in Persons](#)), State and USAID review their country and regional programs to determine which are subject to the TVPA's sanctions and which may be eligible to go forward by relying on other existing authorities.

USAID's [Counter-Trafficking in Persons \(C-TIP\) Policy](#) and [C-TIP Field Guide](#) are a crucial part of USAID's mission, integrated into our CDCSs, RDCSs, and other program-planning processes, and these requirements extend to all implementing partners, including national and sub-national governments. The ranking of a partner government's performance in addressing TIP nationally is a critical eligibility criterion that OUs must review according to the outlined process below to determine eligibility before deciding to use a partner government's systems or institutions to implement development assistance. As explained above, in some cases, assistance to a government will be legally prohibited.

#### **220.3.4 Planning and Designing for the Use of a Partner Government's Systems and Institutions**

Effective Date: 01/13/2021

This guidance describes a typical process (see [ADS 201.3.4](#)) for planning and designing a G2G activity. However, this process is not necessarily sequential or universal. Therefore, teams should follow and adapt the guidelines, as appropriate. It integrates the Agency's risk-management approach and the processes under [ADS 201](#) for an activity's lifecycle.

A financial and development relationship with a partner government is unique in that it is a co-creation process from the start, and it involves shared understanding, responsibility, and accountability on the following:

- Setting clear objectives about the development partnership, with an emphasis on achieving both the activity’s objectives and strengthening the partner government’s systems and institutions;
- Conducting the required due diligence to understand the risks and opportunities associated with the use of the partner government’s systems and institutions and take measures to address them;
- Entering into an agreement that reflects both the mutually agreed objectives and risk mitigation measures to achieve those objectives; and
- Learning and adapting throughout implementation as needed, including monitoring and jointly addressing any challenges that arise.

Missions should adopt a whole-of-Mission and collaborative approach with partner government counterparts and engage in consultations with Washington as part of up-front planning, the execution of the required assessments, the negotiation of G2G agreements, and ongoing implementation and monitoring activities.

#### **220.3.4.1 Overview of Risk Management Approach**

Effective Date: 01/13/2021

Using a partner government’s systems and institutions in implementing development assistance involves a degree of risk that requires additional due diligence to assess the threats and opportunities of such systems and institutions. G2G assistance differs from other forms of USAID assistance in that it relies on a partner government’s systems and institutions for implementation, and the relationship is as an equal partner. This sharing of responsibility means USAID is not in sole control of all decisions, which may present an inherent risk when compared to other awards, but one that USAID is willing to accept because of the benefits, such that G2G assistance allows us to employ a different approach to oversight that acknowledges and mitigates inherent risks through partnership and capacity-development.

The [Circular A-123 published by the Office of Management and Budget](#) (OMB), outlines the definition of “risk” as the “effect of uncertainty on [an Agency’s] objectives.” USAID’s [Risk Appetite Statement](#) articulates a holistic approach to risk as a tool for Missions to use in assessing and addressing risks. It provides broad-based guidance on the amount and type of risk the Agency is willing to accept to achieve our mission and objectives, given consideration of costs, performance, and benefits. The G2G risk management process follows a risk-based approach, it does not aim to control or avoid all risks, but rather to take advantage of opportunities, while reducing or mitigating threats to maximize the overall likelihood of achieving our objectives.

The Agency has adopted a seven-step risk management process consistent with OMB Circular A-123 and described in [Technical Note: Enterprise Risk Management in the Program Cycle](#). The risk management process is not meant to be a stand-alone exercise; rather it is a framework to use in strategic decision-making throughout the planning, design, implementation, and close out of an activity.

USAID's OUs must use the seven-step risk management process throughout the entire lifecycle of a G2G activity, including planning, assessing, designing, implementing, monitoring, evaluating, and CLA. They must follow the seven steps irrespective of funding level and type of agreement; however, they must calibrate the scope and level of effort for each step to reflect the funding level, complexity, and specificity of the G2G agreement (see [How-to-Note: Tailoring the G2G Risk Assessment](#)). In addition, the level of risk identified should drive the actions and appropriate level of effort to mitigate the risk (see [G2G Risk Management and Implementation Guide](#) for more information). The seven steps are:

- Step 1: Establish the Context;
- Step 2: Identify Risks;
- Step 3: Analyze and Evaluate Risks;
- Step 4: Develop Alternatives;
- Step 5: Respond to Risks;
- Step 6: Monitor and Review; and
- Step 7: Communicate, Learn, and Adapt.<sup>2</sup>

The first step for the OU, as part of the G2G risk management process (see [G2G Risk Management and Implementation Guide](#)), is to “Establish the Context.”

**Step 1:** Establishing context is crucial to determining whether the use of G2G is a viable option for the Mission to move forward with the design and further examine inherent risks associated with use of a partner government's systems and institutions (see section **220.3.4.1**). The key deliverable for this step is a Country Context Report, which also includes a statement about democratic accountability, cleared by the PGST and the Mission Director.

When a Mission undertakes a G2G agreement, establishing context should align with CDCS/RDCS planning and the Mission should determine whether such an agreement is viable, given the country context or its indicators on capacity and commitment. This step confirms that the Mission understands the broad range of factors that affect the inherent risks. This step should include considering key information from USAID's [Journey to Self-Reliance Country Road Maps](#), Mission risk profiles, the donor operating environment (to avoid overlap and enhance coordination with the broader

---

<sup>2</sup> Note: Section **220.3.4.1** discusses Step 1, Section **220.3.4.5** covers Steps 2-5, and Section **220.3.6** covers Steps 6-7. Step 7 is not to be confused with the CLA framework. In this context, it applies to communicating, learning, and adapting to the risks associated with G2G assistance.

donor community), other mandatory analyses, and all relevant internal and external assessments to ascertain the viability of G2G assistance. The Mission should scale the scope and depth of analysis to the Mission's familiarity and experience with the partner government's systems and institutions as well as identifying factors that could contribute to fraud, waste, and abuse. Missions can tailor and limit the analysis at this step based on whether a significant change in the partner government's operating environment has taken place since the last relevant assessment, as well as the Mission's level of experience and sophistication with implementing G2G agreements. The Mission should review several factors, including, but not limited to:

- The government's commitment to development, the past relationship with USAID, and the performance of current and previous awards that involve the government as a partner or recipient of funding;
- The government's commitment to the efficient use of, and transparency and accountability for, public resources;
- Existence and quality of policies, legal and institutional framework, and systems and institutions that support the effective use of public and donor funds;
- PFM performance in the sectors and institutions of interest;
- Governance systems and institutions, practices, and factors that affect corruption and fraud; and
- Other political or security factors that represent reputational or fiduciary risk factors (whole-of-USG and within the partner country).

Establishing context as part of the CDCS/RDCS is crucial to understanding early in the process whether the use of G2G is a viable option to proceed with plans for design, including a review of specific G2G risk-assessments, and to understanding the parameters the OU should consider to further guide the activity. The guidance anticipates that the time between establishing context in the CDCS and planning the G2G activity could vary. Depending on this time difference and a desk review re-assessment of the established viability, Missions can use the re-assessed CDCS/RDCS rationale to confirm viability when required during G2G planning (see section **220.3.4.3.**). The planning and design of a G2G activity then follows two phases:

- 1) Phase 1: Planning for the Use of a Partner Government's Systems and Institutions, which confirms eligibility and sets the parameters for establishing a development partnership with the partner government; and
- 2) Phase 2: Steps and Requirements in the Design Process, which involves conducting due diligence, defining the scope of the partnership, and mutually agreeing with the partner government on the way forward.

## 220.3.4.2 Phase 1: Planning for Use of a Partner Government's Systems and Institutions

Effective Date: 01/13/2021

[ADS 201.3.4.5](#) states that Missions should identify a primary POC/design team to lead the process of designing the activity and identify or re-validate high-level parameters to guide the design. Figure 3 depicts this process for a G2G activity.

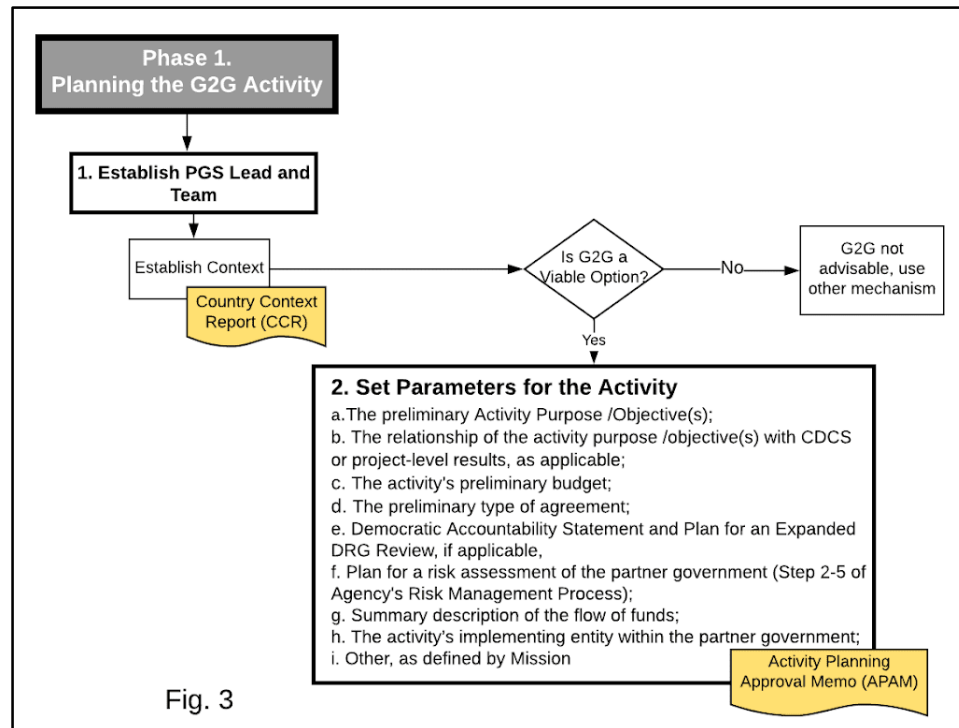

Fig. 3

### 1. Establish the Partner Government System Team (PGST) and Lead

The team approach is a key consideration in managing the design and implementation of a G2G activity. Given the political, technical, programmatic, financial, reputational, contractual, and legal implications of G2G assistance, and the need for effective coordination both within the Mission and with the counterparts in the partner governments, the team approach becomes even more relevant. Once the Mission is considering a development partnership in the form of direct assistance and eligibility criteria have been satisfied, the Mission must establish a PGST and a team lead to manage this process. The role of the PGST and team lead (see [G2G Risk Management and Implementation Guide](#) for more details) will be two-fold:

- 1) Follow the guidance and policy described in this chapter on the planning, design, and implementation of a G2G activity to ensure a successful design and implementation process, including satisfaction of associated requirements; and

- 2) Engage and manage the relationship with the partner government throughout this process given the shared responsibility and accountability of a G2G activity.

Missions should adopt an inclusive whole-of-Mission approach and harness the technical expertise from across the Mission to identify, respond to, and monitor the full spectrum of risks, operationalize the RAS within the Mission context, and balance the internal roles and responsibilities for the ongoing negotiation, implementation, and capacity-development of a G2G activity. The PGST begins by establishing the Mission context and continues through the close-out of the activity with relevant members involved at different points in time, as required. The PGST should clear all the required G2G documentation in the absence of an existing Mission Order on the Mission's clearance process. The Mission Director must establish and document a PGST that includes representation from all required offices in the Mission.

While members of the partner government are not part of the PGST, the PGST should include input from them, at various points in the process and as deemed appropriate by the Mission, to ensure collaboration and buy-in given the collaborative nature of these types of development partnerships.

## **2. Set Parameters for Guiding the Design and Decision on the Use of a Partner Government's Systems and Institutions**

[ADS 201.3.4.5](#) requires the Mission to identify or validate a minimum set of parameters for guiding the design process, which include a preliminary purpose for the activity; how the activity will advance CDCS/RDCS and/or project-level results, where applicable; a preliminary budget; and a preliminary mechanism for implementation (see the [USAID Implementing Mechanism Matrix](#)). In addition to the minimum parameters and mandatory and other technical analysis applicable to the activity described in [ADS 201.3.4.5](#), G2G agreements have some special requirements that relate to the risks associated with using a partner government's systems and institutions in the implementation of the activity. Following the decision on the viability of using a partner government's systems and institutions because of establishing the context, Missions should consider the following:

- A plan for risk assessment, including technical and management capacity (see the [G2G Risk Management and Implementation Guide](#)). Section [220.3.4.5](#) describes a detailed risk assessment, which is required for all, but tailored for each G2G activity.
- Democratic Accountability Statement and an Expanded Review for DRG, as applicable. A statement on democratic accountability, derived from the analysis in the country-context report, will allow the cognizant Mission Director, in consultation as needed with the Regional Bureau AA, DDI/DRG, and other cognizant USG officials, to determine, given the specific country context and

current circumstances, whether the country meets the required standards for democratic accountability and whether an Expanded DRG Review is required.

- A plan for analysis, including specific technical or any other analysis deemed appropriate to guide the design of the G2G activity.
- Implementing entity. Missions should understand the notional G2G implementing entity or entities for the activity, whether the entity is quasi-governmental; contains a project implementation unit; or is a national or sub-national entity, including regional, local, or other units of government. This will help the Mission tailor the risk assessment to the role and functions of the respective entity or entities.
- Flow of funds. Missions should map and understand the notional flow of funds in the proposed activity to identify all financial actors within the partner government's system and their roles to inform the conduct of the risk assessment and the design of the activity (see the [G2G Risk Management and Implementation Guide](#)).
- A plan for audit requirements. Missions must meet the audit requirements for G2G agreements as described in [ADS 591.3.2.1](#). Host governments that spend \$750,000 or more in USAID funding during the course of their fiscal year must have an annual audit of those funds in accordance with [Subpart F and Part 200 of Title 2 of the Code of Federal Regulations \(CFR\)](#) and [ADS 591maa, USAID Financial Audit Guide for Foreign Organizations](#). Missions should ensure they meet any audit requirements specified in any bilateral assistance agreement(s) (BAA). To that end, Missions may find it useful to negotiate and approve one or more Implementation Letters (ILs) with the partner government to provide guidance and implementation details for the specific G2G activity, inclusive of audit requirements and the establishment of an audit plan. While not required, taking this approach may be useful if the Mission feels the need to amplify provisions and requirements related to the audit of USAID funds expended by the partner government. Missions should also note that, as a general rule, a country's supreme audit institution or its equivalent carries out audits of a partner government entity. The Mission must factor such an arrangement into its contextual analysis, implementation, and risk mitigation planning.

### **220.3.4.3 Approval of the Planning and Parameters of a G2G Activity**

Effective Date: 01/13/2021

Phase One consists of planning for the Use of a Partner Government's Systems and Institutions culminates with the planning approval for the G2G activity. The purpose of the G2G planning approval is two-fold:



- 1) Document the viability of using a partner government's systems and institutions in the implementation of the activity, based on the conclusions of the step on Establishing the Context; and
- 2) Set the parameters that will guide the design of the G2G activity, as described in section **220.3.4.2**.

The Mission Director or designee must approve the planning of the G2G activity and identified parameters through an action memorandum (see [ADS 220mal, G2G Activity Planning Approval Memorandum \(APAM\)](#)).

#### **220.3.4.4 Phase 2: Steps and Requirements in the Design Process**

Effective Date: 01/13/2021

During Phase Two, the activity design process, the Mission designs the G2G activity based on the parameters identified during Phase One. The design process starts with gathering and analyzing information that will inform the programmatic decisions related to the results the activity should achieve, alongside risk appetite and risk tolerance levels associated with use of a partner government's systems and institutions (see [G2G Risk Management and Implementation Guide](#)).

The most important aspect of the design phase is close collaboration and consultation with the partner government in establishing the analytic agenda and design, as the team at the Mission identifies the risks and opportunities and co-designs solutions in partnership. The outcome of this co-design process ensures shared responsibility and decision-making, as well as ownership and accountability on the part of the partner government.

This section provides guidance on the design process for a G2G activity, during which the Mission integrates all these analyses when making decisions on the way forward (see Figure 4). Missions have the option to design a project that could include a G2G mechanism as well as other interrelated activities; this can occur if G2G activities require capacity-building or other support that needs to come from an allied contract, grant, or cooperative agreement, or in other instances the Mission may integrate a policy reform effort directly into a project's broader objective. In these instances, a Mission may manage a G2G activity better within a project's framework. If a Mission wishes to follow this option, it must use the guidance outlined in [ADS 201.3.3](#).

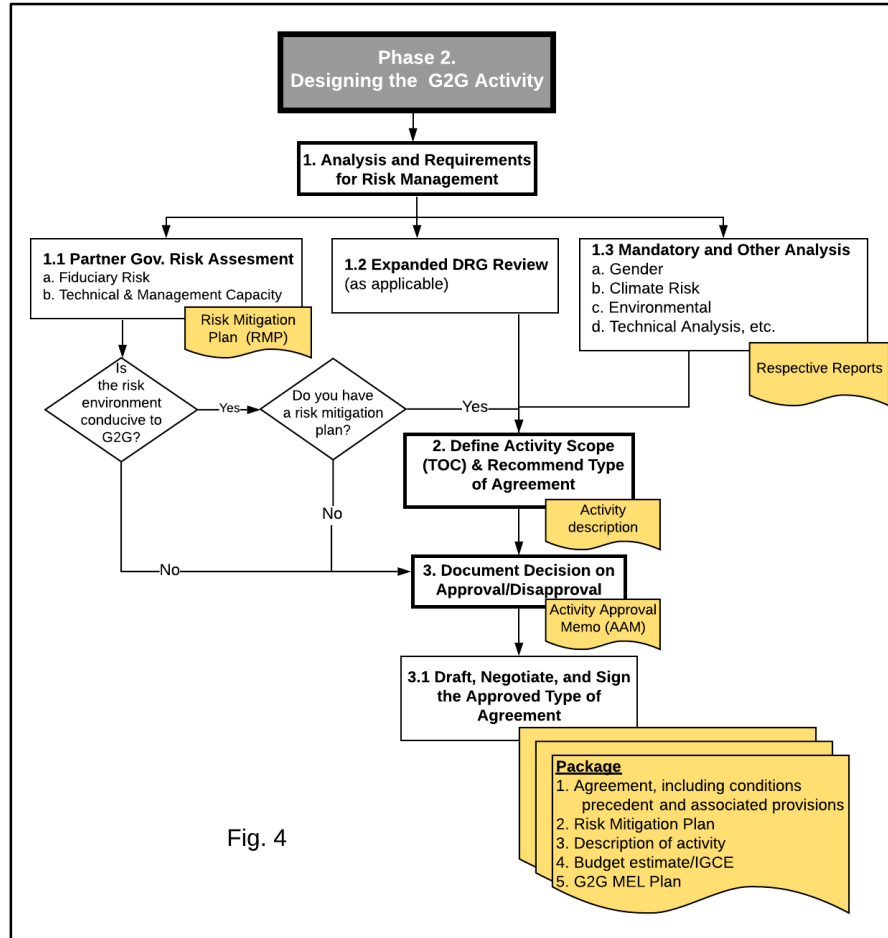

Fig. 4

### 220.3.4.5 Analysis and Requirements for Designing and Managing the Risk of a G2G Activity

Effective Date: 01/13/2021

The analytic agenda for the design of a G2G activity must include, but is not limited to, the following:

- An assessment of the PFM, governance, and/or public accountability systems and institutions of the partner country government at the level and the offices that are relevant and applicable to the activity;
- An assessment of the relevant institutional technical capacity of the entity or entities that will implement the activity;
- An expanded DRG Review, as warranted, following the parameters in section **220.3.4.2**;

- Analysis for gender, climate risk-management, and environment, as required in [ADS 201.3.4.5](#); and
- Assessment of partner government’s systems and institutions for monitoring and evaluation, as relevant and applicable to the activity.

The analytic agenda also should include other issue- or sector-specific assessments, including specific assessments of community and civil-society needs, and studies or data conducted or disseminated by other organizations or researchers, as available and relevant. When a G2G activity falls under a project framework, as applicable, the team should consider how other activities within the project can support the G2G activity, or how to integrate a policy reform effort into a broader objective of a project.

These assessments will provide information on relevant systems and institutions, operations, and internal controls, and will identify risks of the G2G activity and guide the development of the associated risk mitigation options for the proposed activity. They will also highlight the best course of action to address the development challenge and, in collaboration with the partner government, define the way forward.

Missions should use or build on existing assessments completed by other USG actors, donors, or stakeholders (if these are relevant and up-to-date, and there have been no major changes in the government’s systems and institutions since the assessments were conducted), subject to meeting the legal and policy requirements outlined in this chapter. The PGST, to the extent possible in collaboration with the partner government, should augment these existing assessments with focused questions to understand possible risks and opportunities further. The goal is to ensure that risk assessments are tailored and targeted, and not overly broad or time-consuming (see [G2G Risk Assessment and Implementation Guide](#)).

## 1. Partner Government Risk Assessment

In addition to the government-wide eligibility criteria described in section [220.3.3.1](#), [section 7031\(a\)](#) of the annual SFOAA and section [220.3.2](#) also require that the partner government entity or ministry that will receive the funds has the systems and institutions required to manage such assistance, regardless of the type of agreement or amount (see Figure 5). Missions must assess the risk environment and tailor risk assessments to verify the following aspects:

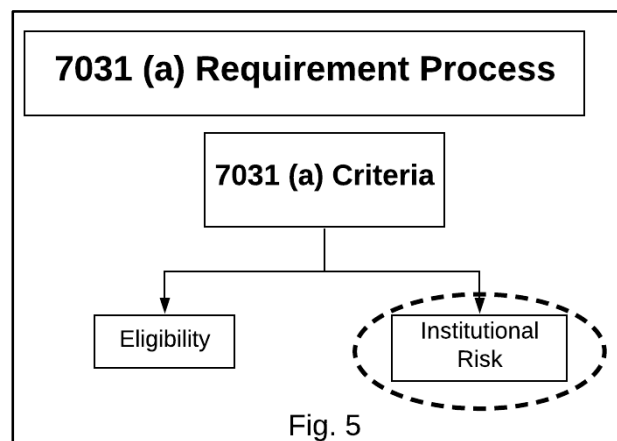

- The recipient government entity or ministry employs and uses staff with the necessary technical, financial, and management capabilities;
- The recipient government entity or ministry has adopted transparent, competitive procurement policies and systems; and
- Effective systems for monitoring and evaluation are in place to ensure that USG funds go for their intended purposes.

Section 7031(a) of the SFOAA states there is no acceptable level of fraud. This is intended to provide a reasonable standard for the conduct of OUs' risk assessments. It does not require the mitigation of every risk, no matter how small or in what area, nor does it require a separate fraud assessment. USAID implements this provision through application of our ERM approach. For example, a Mission may accept a medium technical/programmatic risk but only a low fiduciary risk (see [G2G Risk Management and Implementation Guide](#)).

The seven steps in section **220.3.4.1** are part of the Agency's risk-based approach to a spectrum of risks and assist Missions to assess and manage G2G risks, including, but not limited to, fiduciary, technical, and reputational ones (see [G2G Risk Management and Implementation Guide](#)).

Fiduciary Risks: "Fiduciary Risks" is one of the risk categories managed by the Agency and, with respect to G2G, is defined as the danger that funds allocated from our budget:

- 1) May not be controlled properly;
- 2) May be used for purposes other than those intended; and/or
- 3) May produce inefficient or uneconomic programmatic results.

Reputational Risks: In addition, the determination of eligibility in section **220.3.3.1** is the first opportunity to assess a partner government's systems and institutions to determine potential events or circumstances that could improve or compromise USAID's reputation, standing, or credibility. An Expanded DRG Review, as warranted, examines further the context of a weak or worsening environment for democratic accountability, and determines if the Mission:

- 1) Deems the planned G2G assistance to be appropriate given governance risks and must consider such risks in its design (see [Guidance for the Expanded DRG Review](#)); and
- 2) Could leverage the G2G activity to incentivize greater commitment to democratic accountability.

However, reputational risk is much broader than risks discussed in the DRG review. It may involve actions that our partner governments may take that compromise USAID's standing or credibility with Congress, the interagency, the American public, multilateral institutions, implementing partners, beneficiaries, or other stakeholders (see [G2G Risk Management and Implementation Guide](#)).

Technical and Management Capacity Risks: Understanding the technical and management capacity of the government entity or entities that will implement the agreement activities is critical to the success of the implementation of the sector-specific outcomes, which is the reason for embarking on the G2G agreement. A technical assessment should indicate the strengths and weaknesses of the systems and institutions to deliver on sector targets, outcomes, and goals with quality and equity; and indicate the ability of the system to report on technical data to track progress in a valid and reliable manner and to course correct as needed in response to new learning or contextual shifts. Missions should tailor these assessments to the specific-sector goals of the G2G, not the whole sector or technical area. If the analyses uncover weaknesses, Missions should provide focused capacity-development for technical success, either as part of the scope of the G2G agreement or by outside-capacity development providers. It is important to emphasize that:

- 1) Entering a funding relationship with a sovereign entity can limit the mechanisms on which USAID can rely to control fiduciary, technical, and reputational risks as it does with its other traditional implementing partners. Due diligence for these partnerships requires that the Agency pay special attention to, and assess and mitigate, such risks.
- 2) While fiduciary risk assessments, technical risk assessments, and the Expanded DRG Review for G2G assistance may be different from USAID's traditional approaches, they do not necessarily cover all possible risks. In addition, Missions should approach the risk assessment process in the spirit of partnership, since it is a measurement of the risks presented to achieve the mutually agreed development objective(s) with partner governments while using their systems and institutions.

## 2. Other Analyses That Inform the G2G Design

Besides specific risk assessments of a partner government's systems and institutions, other analyses can reveal more detailed information on sectoral priorities and requirements, including other policy priorities, and operational approaches and mandatory analysis at the activity level. These include mandatory analyses for gender, climate risk management, environment, and, as applicable, a political economy analysis, and an analysis of the private sector landscape (see [ADS 205](#), [ADS 204](#), [ADS 201mal](#), and [ADS 201.3.4.6](#)). For a more comprehensive list of analysis that the design team may choose to conduct, typically after informal consultation from the partner government, see [Compilation of Analyses and Assessments](#).

### 3. Risk Management Approach

Missions must identify both the opportunities and risks of providing development assistance in partner countries, while also ensuring that they detect, prevent, and address risk factors in accordance with the Agency's risk management approach. The identification and analysis of, and response to, risks outlined in the G2G risk management process should also include the assessment of fraud risks and the consideration for the potential of internal and external fraud, as required by the [Standards for Internal Control in the Federal Government \(the "Green Book"\)](#) published by the Government Accountability Office (GAO) and outlined in the [GAO's Framework on Managing Fraud Risk](#). As with other risks, the assessment should include the likelihood and impact of risks, including the impact of fraud risks on all aspects of the activity's objectives. The [G2G Risk Management and Implementation Guide](#) provides more details on the risk management applicable to this section, as described in Steps 2 through 5.<sup>3</sup>

**Step 2: Identify Risks.** This step allows the Mission to ascertain and enumerate all risks related to the envisioned G2G activity. Where applicable (see section [220.3.3.1](#)), an Expanded DRG Review supports the identification of reputational risks in countries with weak or deteriorating democratic environments (see [Expanded DRG Review Guidance](#)). The deliverable for this step, which is an optional part of the risk assessment report, is a risk log that identifies all risks pertinent to the envisioned activity and assigns them a risk category or theme. Risks identified in prior assessments conducted by the Mission or other donors or USG Departments or Agencies are applicable when the standard of such assessment is in line with this chapter.

**Step 3: Analyze and Evaluate Risks.** Missions should analyze, evaluate, and prioritize all identified risks in a risk matrix as Critical, High, Medium, and Low, based on the probability or likelihood that each risk could materialize and the impact it would have on the G2G activity's objectives. The key deliverable for this step, which will be part of the risk assessment report, is a list of prioritized risks evaluated against the G2G activity's objectives.

**Step 4: Develop Alternatives.** Missions should develop risk mitigation strategies based on the prioritized ranking developed in Step 2. In collaboration with partner governments, Missions should come to a consensus on the methods and strategies that will influence the likelihood or impact of the identified risks. This can include establishing conditions, precedents, or concurrent and response scenarios that the implementing entity or entities and the Mission can take to address the root cause of the risks. Such methods and strategies should aim to address or mitigate the risks identified and should be appropriate to the size and dollar amount of the activity. The key deliverable for this step (and Step 5 below) is a Risk Mitigation Plan (RMP) and, as applicable, a Capacity Development Plan that will provide a synopsis of

---

<sup>3</sup> Note: Step 1 of the Agency's risk-management process is "Establish the Context," discussed in [220.3.4.1](#).

assessment observations with risk response strategies associated with each identified risk.

**Step 5: Respond to Risks.** The list and selection of the response methods and strategies identified in the previous step informs the creation of an RMP and, as applicable, a Capacity Development Plan, including specific technical risks and, where applicable, the risk mitigation measures identified through an Expanded DRG Review.

As a key deliverable for appropriate risk response, the risk mitigation and applicable Capacity Development Plan, among other considerations, will inform the final choice of agreement to use, and the Mission will incorporate them into the actual agreement and associated documents.

#### 4. Risk Mitigation Plan and Capacity Development Plan

[Section 7031\(a\)](#) of the SFOAA and section **220.3.2** of this chapter require that “each implementing agency or ministry to receive assistance has been assessed and is considered to have the systems required to manage such assistance and any identified vulnerabilities or weaknesses of such agency or ministry have been addressed.” G2G assistance requires an RMP, an important deliverable of Step 5 above, to address identified vulnerabilities or weaknesses in accordance with USAID’s ERM approach.

The Mission should co-develop and negotiate the RMP with the partner government’s implementing entity or entities (see the [G2G Resource Library](#) for examples). In addition to the plan, Missions may identify areas to strengthen the capacity of the partner government’s systems and institutions, either as part of the G2G activity being designed or through other complementary activities. Missions may develop a Capacity Development Plan to describe such needs, in conjunction with the RMP or separately, and document actions on capacity-development efforts.

- The Mission must include and approve the RMP and, if applicable, the Capacity Development Plan in the Activity Approval Memorandum (see [ADS 201mai, Activity Approval Memo \(AAM\) Template](#)) that will approve the G2G activity and the use of a partner government’s systems and institutions. The contents and sufficiency of the RMP must represent the independent recommendation of the PGST and the judgement of the Mission Director. The AAM serves as the Mission’s documented due diligence related to G2G activities and authorizes the Mission’s use of a partner government’s systems and institutions in the implementation of such activities.
- The Mission expressly must incorporate all risk mitigation measures, *i.e.*, the specific actions that USAID and/or the partner government agree to undertake to mitigate each risk, and related risk indicators, into the type of agreement chosen as the most appropriate for the implementation of the G2G activity (see section **220.3.5** for the different types of agreements).

- As part of this process, Missions have an opportunity to articulate and refine their capacity-development efforts or areas where they may strengthen local institutions and further advance broader sectoral or self-reliance objectives.
- The GATR must upload the RMP and relevant documentation related to the G2G risk management process into the Agency Secure Image and Storage Tracking System ([ASIST](#)) (Consolidated Audit and Compliance System (CACS)) after the Mission Director's approval. The M/CFO risk-management team must conduct routine queries of the system to ensure Missions submit all required documentation. For assistance on the development and maintenance of the RMP and the Capacity Development Plan, along with illustrative examples, please refer to the [G2G Risk Management and Implementation Guide](#).

#### **220.3.4.6 Defining the Scope and Implementing Mechanism for the G2G Activity**

Effective Date: 01/13/2021

##### **1. Defining the Activity's Scope and Capacity-Development**

The information and evidence gathered through the risk assessment and other programmatic assessments relevant to the activity help the PGST define the desired change in the system and articulate the type of interventions required, both programmatic and operational. The G2G activity scope will describe the actions to improve the performance of the partner government's actors and systems and institutions with which USAID is engaging in achieving the mutually agreed objectives. This information helps the PGST formulate a Theory of Change for the activity, described in the draft activity description, and make a determination on the capacity of partner government systems and institutions such that:

- 1) It recommends approval to provide direct assistance as described in the activity description, which may also include capacity-development, as described in the Capacity Development Plan and in conjunction with the RMP, to strengthen capacity as part of the activity; or
- 2) It recommends that the Mission considers further actions for capacity-development, which may strengthen or aid the use of a partner government's systems and institutions (see [G2G Risk Management and Implementation Guide](#) for illustrative examples on capacity-development). Where such capacity-development efforts become a development goal, Missions should build them into the Capacity Development Plan, and address them in a variety of ways, including, but not limited to:
  - a. Working with contractors and recipients to strengthen the country's systems and institutions and accountability through acquisition and assistance;



- b. Working with other donors to strengthen the partner government's systems and institutions through ongoing coordination and harmonization efforts (see section **220.3.2**); Missions may consider coordinating with other bilateral and multilateral donors (also referred to as PIOs) on joint funding arrangements, and other coordination measures such as those in [ADS 308](#) and [ADS 351](#) as part of the design process (see [ADS 201](#)) and, as applicable, pooled funding arrangements (see [ADS 308](#)); and
- c. Working with USAID's staff, including, but not limited to, financial management staff, to strengthen the country's financial management systems and institutions, information technology, policy reform, or other systems and institutions with which USAID has familiarity, expertise, and capacity to support.

In defining the activity's scope and Theory of Change, the PGST establishes the specific results the partner government should achieve, as well as a set of actions that their analysis has suggested will lead to those results. In addition, and in collaboration with partner government counterparts, the Mission should identify preliminary performance measures and plan for achieving such results. Planning for monitoring, evaluation, and CLA should be part of the discussions and agreement on the activity's scope and Theory of Change incorporated into the final G2G agreement.

## **2. Selection of Partner Government Implementing Mechanism**

G2G activities may employ a variety of funding mechanisms to finance the approved interventions. The Mission must base its choice of the appropriate funding mechanism on a clear statement of the activity's overall purpose and the recommendations in the RMP. Before selecting and negotiating a particular implementing mechanism with a partner government's entity, Missions should identify all the mechanisms available for the G2G activities (see section **220.3.5**) and understand the positive and negative aspects of each mechanism. Often, more than one implementing mechanism may be able to achieve the activity's purpose. The Mission should select the most appropriate partner government implementing mechanism by determining, among other things:

- What development outcomes the Mission seeks, and which type of assistance lends itself to best achieving and sustaining them in the future;
- The relationship with the national or sub-national government and the implementing entity or entities;
- The technical capacity and institutional strength of the implementing entity or entities;
- The results of the risk assessment, and which choice has the potential to deepen PFM capacity and limit negative risk exposure and potential fraud, waste, and abuse;

- Management burdens on resources in the Mission and partner government; and
- The applicability, availability, and accuracy of input cost data for a FARA.

#### **220.3.4.7 Approval of a G2G Activity and the Use of a Partner Government's Systems and Institutions**

Effective Date: 01/13/2021

After the Mission has completed all necessary assessments and requirements, and risk mitigation measures justify the use of a partner government's systems and institutions, teams must prepare the [Activity Approval Memorandum \(AAM\)](#) for the Mission Director to:

- 1) Approve the G2G activity and use the partner government's systems and institutions for the implementation of direct assistance, based on the conclusions and recommendations of the required risk assessment(s); and recommend the most appropriate funding mechanism (see section **220.3.5**); or
- 2) Disapprove the use of the partner government's systems and institutions, and give a justification for why the G2G assistance is not appropriate at this time, and any actions, as applicable, to improve their capacity for direct assistance in the future (see section **220.3.4.3**).

Once the Mission Director has approved, the Mission moves forward with drafting the G2G agreement and the required documentation prior to obligation of funds.

#### **1. Draft the Agreement Identified for Implementation**

After the Mission Director has signed the AAM, the PGST and, in particular, the lead of the design team should develop a draft G2G agreement that takes the form of a sub-obligating IL under a DOAG, or a direct obligation in the form of another type of BAA (see [ADS 350](#) and section **220.3.5** for templates of each type of agreement). In drafting the agreement, the team lead should use the approved (if the Mission Director approves it) activity scope and other risk mitigation measures. This agreement should include a description of the G2G activity, informed by the activity's Theory of Change; the RMP that details specific response measures agreed with the partner government; and other terms and conditions respective to each agreement (see [The Role of the DOAG and IL in Funding G2G Activities](#)). The PGST should develop a detailed budget and define a disbursement option (e.g., Cost Reimbursement or FARA, based on the findings and decisions documented in the RMP (see section **220.3.4.5**)).

In addition, the PGST should include reporting requirements in the agreement, such as possible periodic development or joint approval of annual work plans. If the plan for the mitigation of fiduciary risks annexed to the AAM includes actions the partner government will take over time, teams should include these mitigation measures, along with requirements to report against progress.

Missions have discretion to determine who clears or approves the draft agreement. Since there is no competitive award process in G2G assistance, the PGST should discuss the agreement with staff from the partner government so that it best reflects a co-design approach.

## 2. Negotiate Agreement with the Partner Government

The success of bilateral development assistance hinges on maintaining a relationship of equal partnership between two sovereign entities. USAID personnel must engage with their counterparts in the partner government with the highest degree of professionalism, collegiality, diplomacy, and collaborative intentions.

### a. USAID Representatives and their National Counterpart(s)

Once the Mission has cleared the draft agreement internally, formal negotiations of the draft agreement can begin with officials from the partner government, although informal negotiations should have occurred during the drafting of the IL. Missions should define a negotiating team, composed of members of the PGST, with clear roles for each team member. Frequently, the RLO or the Technical Office will lead this team, although other team members could play this role. In addition to the text in the draft agreement, the technical lead, in collaboration with the members of the PGST, should use this process to discuss the roles and responsibilities of USAID and the partner government, including counterpart funding, conditions related to disbursement, and other significant issues. Before the negotiation process, both USAID and the partner government must assign designated officials authorized to negotiate and sign the agreement.

- i. Designated Representative. The Mission Director/Principal Officer serves as the designated U.S. Government representative for the BAA. After the approval of G2G activities, Mission Directors/Principal Officers are responsible for negotiating, signing, administering, and, if needed at the implementation stage, amending, suspending, or terminating an approved G2G activity with the partner government. Pursuant to [ADS 103, Delegations of Authority](#), only the Mission Director/Principal Officer or other delegated officer has the authority to:
  - Execute the BAA, and/or IL, and
  - Approve and execute amendments to the BAA/IL.
- ii. Delegations of Authority. Mission Directors/Principal Officers may designate additional representatives from the Mission to manage the project and establish long-term, professional relationships with counterparts in the partner government. These delegations may include the authority to:
  - Sign ILs; and

- Take formal implementation actions under a BAA.
- iii. Additional Authorized Representatives. The Mission must notify the partner government, in writing, of the USAID personnel and their delegated authorities as Additional Authorized Representatives under the agreement.

Because of the inherently governmental functions involved, individuals designated as delegated representatives of USAID for the agreement and/or implementation and management of the project activities must be USAID personnel (U.S. Direct-Hires or Personal Service Contractors (PSCs), subject to restrictions under [ADS 103.3.1.1.d](#) and warrant limitations).

Considerations to Create Incentives for Increasing Commitment from the Partner Government:

- a. Conditions Precedent: Missions should, as applicable, introduce conditions precedent to funding for G2G to encourage commitment from the partner government. Missions can capture such conditions in [ADS 350mac](#) or an IL. Conditions precedent must follow the procedures in [ADS 350](#).
- b. Cost-Share: Section 110 of the Foreign Assistance Act (FAA) of 1961, as amended, requires the partner government make a contribution of 25 percent for all USAID projects funded from the Development Assistance account, with resources for childhood survival and health, and certain other categories of appropriated funds, when the bilateral assistance would result in benefit to, and the involvement of, a partner government. The Mission must memorialize this requirement in the DOAG or stand-alone G2G agreement negotiated with the partner government (see [ADS 350](#) for further information on the contribution requirement). In addition to the statutorily mandated contribution, Missions should build cost-share arrangements into G2G agreements and maximize the commitment of the partner government.

### 3. Sign Final Agreement Upon the Satisfaction of Pre-Obligation Requirements

Once the Mission agreement has negotiated the G2G agreement, the PGST should clear the text internally based on Mission-specific procedures. The PGST should ensure the satisfaction of all remaining pre-obligation requirements, as applicable and appropriate, including those in Section 7031(a) of the annual SFOAA.

Mission Directors have delegated authority to obligate USAID's funds through agreements with partner governments. The partner government will determine the officials responsible for signing on its behalf. Frequently, the government will designate a representative from the Ministry of Finance or another central authority, in addition to the involved line ministry or office.

#### 220.3.5 Types of Partner Government Implementing Mechanisms

Effective Date: 01/13/2021

USAID's Missions may implement G2G activities through a variety of instruments through which the Agency can obligate funding directly to a partner government entity by using any BPA agreement pursuant to [ADS 350](#), but it is most common for funds for Missions initially to obligate funds bilaterally through a DOAG, and then sub-obligate them for specific activities to a partner government implementing entity via an IL (see [The Role of the DOAG and IL in Funding G2G Activities](#)). USAID's funds are subject to source and nationality requirements for any contract for supplies or services entered into by using USAID funds, according to Section 604(a) of the FAA, as implemented by USAID's regulations at Part 228 of Title 22 of the CFR. The implementing mechanism agreement must specify the authorized geographic code for source and nationality of contractors; the default geographic code is 937 (United States, partner country, or other developing country). These requirements do not apply to funds subject to authorities other than the FAA, which may have their own restrictions (see [ADS 305](#) and its Mandatory References).

The types of partner government implementing mechanisms vary, and they depend on the objectives of the G2G activity. The two primary partner government implementing mechanisms are Cost Reimbursement Agreements (used to finance specific inputs) and FARAs (used to finance the completion of specified outputs). USAID, in collaboration with partner government, must identify all inputs or outputs during the design of the activity and budget for them in the activity's cost estimate. Budget tables are part of the obligating or sub-obligating documents, to facilitate implementation and ensure transparency. These should be sufficiently detailed to meet the U.S. Government's requirements for estimating the costs of the activity. The following describes each one of these implementing mechanisms in more detail:

- 1) **Cost Reimbursement Agreement:** A Cost Reimbursement Agreement is a form of assistance in which USAID reimburses the partner government entity for its actual costs and expenditures incurred in carrying out the project or activity:
  - a. Missions must identify the inputs and the estimated costs of inputs that USAID and the partner government will finance in the DOAG or a BPA and budget for them in the PDD or the activity's cost estimates (see [ADS 201](#));
  - b. Budgets must provide sufficient detail to justify the level of financing approved by the Mission;
  - c. For activities jointly approved by USAID and the partner government outside of the government's budget cycle, or when funding from the partner government is not available, USAID may provide advance funding under [ADS 220maj, Advances for G2G Assistance](#), and the following conditions:
    - In conjunction with cost reimbursement projects on a revolving (advance/liquidation) basis (see [ADS 636](#)); and

- A determination by the Mission that:
    - Adequate funding will become available within the partner government's budget to implement the project on a reimbursement basis;
    - The overall capacity of the partner government to implement activities under this mechanism is adequate; and
    - Advance funding will meet the Mission's programmatic priorities; and
  - Continued funding is subject to periodic review and approval by USAID.
- d. USAID agrees to pay reasonable, allowable, and allocable actual costs up to the amount sub-obligated for the activity, and subject to periodic reviews of satisfactory progress under the activity.
- e. Additional policy and guidance on the use of Cost Reimbursement Agreements for G2G assistance appears in [ADS 220mag, G2G Implementing and Funding Mechanisms Cost-Reimbursement Projects](#).
- f. Missions should follow the [Cost Reimbursement Implementation Letter Template](#) in drafting their ILs.
- 2) Fixed Amount Reimbursement Agreement (FARA): A FARA is a form of assistance under which USAID provides a fixed amount without regard to the actual costs incurred under the agreement, based on a reasonable estimate of the cost projected for the agreement. The fixed amount is the amount agreed to, and fixed in advance, in the IL/BAA, which does not change based on the partner government entity's actual incurred cost. USAID has several ways to provide the fixed amount to the partner government, including the following:
- Several partial payments, where the amount of each payment is agreed upon in advance based on the completion of specific milestones or outputs;
  - Unit prices, where payment is based on defined units at defined prices agreed to in advance; or
  - One payment after the completion of all outputs, works, and activities under the agreement.

The IL/BAA must also establish quality standards or criteria for each output or milestone the partner government must meet, as verified by USAID or its representative, prior to reimbursement. USAID may rely on the documented input of a USAID-funded contractor to confirm appropriate or cost reimbursement completion.

- a. The requirements for using a FARA are the following:
  - Outputs or milestones must:
    - 1) Be objectively verifiable regarding completion and quality;
    - 2) Be, or contribute directly to, sustainable and independently useful outputs, regardless of whether other outputs or activities are completed;
    - 3) Be paid for in amounts based on reasonably accurate, documented cost estimates:
      - a. USAID may not price outputs or milestones to provide liquidity, and must base the payment amount for each output or milestone on a reasonable and documented estimate of the output's or milestone's cost; and
    - 4) Be within the partner government's span of management control to complete successfully as designed.
  - The partner government entity should be likely to complete each output or milestone in less than 18 months from the initiation of work, although some variation in timing could result from the nature of outputs or milestones contemplated and actual implementation experience.
  - USAID must base the payment amount for each output or milestone on the following:
    - 1) A detailed and reasonable estimate of its cost (or a percentage thereof); and
    - 2) Documented verification by USAID of the completion of each output or milestone.
  - Programmatic risk increases as the partner government entity assumes a significant portion of the financial risk for actual costs under a FARA:

- 1) Therefore, USAID must assess and determine that the management and budgetary capacity of the partner government entity is sufficient to produce the financed outputs or milestones under a FARA before a Mission may obligate or sub-obligate funds for a FARA.
  - 2) USAID may conduct this assessment as part of the technical capacity analysis required by [ADS 201](#) or combined with the fiduciary risk assessment. When a Mission combines the technical analysis with the risk assessment, the SOW and report should provide separate sections that cover fiduciary and technical matters.
- b. Additional policy and guidance on the use of a FARA appears in [ADS 220mah, G2G Implementing and Funding Mechanisms Fixed Amount Reimbursement](#).
  - c. On an exceptional basis, as justified, Missions may provide advances under a FARA, where necessary, so long as they liquidate the advances based on the successful completion of outputs or associated milestones rather than actual costs incurred. Associated milestone payments must be refundable if the partner government entity does not complete the final output.
  - d. A FARA can include the periodic adjustment of subsequent output or associated milestone payment amounts based on changed conditions, such as price escalation or unforeseeable inflation. Such adjustment, to the maximum extent possible, should not be retroactive to works in progress or previously completed. For additional guidance on this matter, Missions should refer to [ADS 3176s, Use of Fix Amount Reimbursement Method for Local Cost Financing](#). Missions must document such adjustments and modify ILs in writing.
  - e. Missions should follow the [Fixed Amount Reimbursement Implementation Letter Template](#) in drafting their IL or BAA.
  - f. FARA payment options: Missions may use FARA to finance complex, non-serial, or non-capital outputs, so long as each output meets the necessary requirements as outlined in section 2.a.i. In these cases, the Mission can structure the outputs or associated milestones and corresponding payment amounts in the IL as a range or sliding scale so long as the payment amount corresponds to the estimated cost of each performance level in the range. The scale must be well defined and quantified clearly and adequately. The pre-established reasonable cost estimate will still serve as the payment cap for the achievement of the highest result target. This is labeled a “Level 1” payment in the milestone



payment schedule. Reduced achievement of the milestone within a pre-determined range will trigger a pre-calculated reduced payment, labeled on the milestone payment schedule as successively reduced levels of payment. For example: Level 1 is meeting or exceeding the target (full payment); Level 2 is 95-99 percent achievement (five-percent less than the full payment); Level 3 is 90-94 percent achievement (10 percent less than the full payment); and Level 4 is less than 90 percent achievement (zero payment).

- 3) Other Implementing Mechanisms:** Other types of partner government implementing mechanisms, known as “program assistance” or “non-project assistance” (see definition and [Program Assistance Policy](#)), include Sector Program Assistance (SPA) agreements and General Budget Support or Balance of Payments/Cash Transfers, which represent generalized resource transfers, in the form of foreign exchange or commodities, to the partner government to alleviate constraints that are policy- or resource-based. Under this approach, individual transfers of funds depend on the completion of performance benchmarks by the partner government, and USAID disburses funds after the partner government has completed such benchmarks. The amount of these non-project assistance transfers does not depend on either the estimated or actual cost of any reform or performance benchmarks.
- a. Sector Program Assistance:** Missions may consider SPA to achieve broad-based, measurable sectoral development results via medium- to long-term increases in production or efficiency in a defined economic or social sector or sub-sector. Such assistance must be contingent on certain partner government actions necessary to further or achieve agreed upon development objectives at the sectoral level, such as new policy or institutional reform. These programs are generally appropriate when the purpose is to transform a particular sector (*e.g.*, agriculture, health) and the main constraints to achieving significant sectoral development results require a mixture of institutional improvements, policy changes, and budget expansion. Missions often combine SPA approaches with cost-based assistance activities that provide technical assistance, or complementary sectoral project investments in infrastructure, training, etc. (see [ADS 220sai, Sector Program Assistance Agreement Template](#)). Additional policy and guidance on the use of SPA appears in USAID’s [Program Assistance Policy](#).
  - b. General Budget Support or Balance of Payments (BoP/Cash Transfer):** BoP/Cash Transfer is a modality primarily aimed at promoting economic and political stability by bridging short-term shortfalls in a country’s public-sector budget and/or BoP. In appropriate cases, Missions may combine this assistance with, or condition it upon, institutional or policy reforms, usually in fragile states and strategic partners. The time horizon for this type of resource transfer program can be short-, medium-, or long-term, depending on the structural nature of the resource shortfalls. Because the

amounts of these transfers do not depend on the costs of achieving measured development results, USAID normally finances such programs from the Economic Support Fund (ESF), and they have a generally high level of USG or international interest (see [ADS 220saj, Balance of Payments/General Budget Support Assistance Agreement Template](#)).

These are a few considerations related to the SPA and BoP/Cash Transfer implementing mechanisms:

- The Program Assistance Agreement must identify the end use of the dollar resources, and they must be tracked and auditable to their end uses. Actions the partner government will take are part of the obligating bilateral Program Assistance Agreement as conditions precedent to disbursement. Dollar resources are provided via a cash transfer after the conditions precedent are met.
- Usually, the SPA and BoP/Cash Transfers implementing mechanisms involve host-country-owned foreign currency generated, set aside, or required to be deposited under program assistance agreements such as Commodity Import Programs, Sector Program Assistance agreements, Cash Transfers, and Programs under P.L. 480. This chapter uses the terms “host country-owned foreign currency,” “local currency (LC),” and “host government-owned local currency” interchangeably, but [ADS 624](#) covers and governs them.
- If the U.S. dollar disbursements under the Program Assistance Agreement do not generate local currency (*e.g.*, through the sale of foreign exchange or the purchase of commodities), a separate deposit of host country-owned local currency (HCOLC) may still be a requirement stipulated in the G2G agreement. However, a separate HCOLC deposit is not a U.S. legal requirement. The Mission must deposit any generated or deposited HCOLC into a separate Special Local Currency bank account. USAID and the partner government will make joint decisions about using the HCOLC for programming, in accordance with USAID’s policy and guidance on local currency programming. USAID typically uses the generation (or deposit) of HCOLC when the Agency wishes to be involved more closely in ensuring the allocation of funding to specific sector budgets or budget line items, such as for Sector Program Assistance. This increases USAID’s management responsibility for the program, but also allows the Agency to influence the partner government’s budget for the target sector in a meaningful way.
- Performance Actions by the Partner Government: The performance actions must be part of the G2G agreement directly or by reference as conditions precedent to the disbursement of USAID funds under a Program Assistance Agreement. Performance actions must be verifiable, comprehensive, meaningful, and achievable. Prior to each disbursement of funds, the Mission must prepare documentation that explains how the partner government met (or did not meet)

each performance action and how the Mission made its decision to disburse (or withhold disbursement).

- **Disbursement:** Once the partner government meets the performance actions or conditions, USAID disburses U.S. dollars to it. USAID generally disburses appropriated funds to a partner government into a bank account that the partner government owns and holds in an acceptable correspondent bank in the United States, preferably the Federal Reserve Bank. In rare circumstances, USAID may justify and notify in a Congressional Notification that the Agency intends to authorize an exemption to the requirement to disburse funds into a separate dollar account. Advances of appropriated funds are not authorized for program assistance.
- **Congressional Notification (CN):** A CN is required for these types of partner government implementing mechanisms that are separate from, and additional to, those required for G2G assistance and other USAID-funded programming.

Because of the above differences in how USAID obligates and manages program assistance, Missions must obligate funds for program assistance separately from project assistance in a Program Assistance Agreement; Missions may not sub-obligate program assistance under a project assistance instrument such as a DOAG.

- 4) Trust funds managed by a partner government (multi-donor trust funds or “basket funds”):** While many multi-donor approaches involve a lead donor or PIO trustee and USAID implements them under [ADS 308](#) and [351](#), partner governments themselves do manage some multi-donor funds. If this is the case, and the funds will use the partner government’s PFM or other systems and institutions to implement development activities, the policies and procedures of this ADS chapter apply to the fund. PGSTs should attempt to coordinate with, and rely upon, assessments by other contributing donors of the trustee’s financial and other oversight capacity and risks. Missions must ensure that such other donors’ efforts are compatible with, and sufficiently meet the processes and requirements of, this ADS chapter.
- 5) Host-Country Contracts:** A Host Country Contract is a means of program implementation in which USAID finances, but is not a party to, contractual arrangements between the host government and the supplier of goods and/or services. Although broadly related to the implementation of a G2G agreement, a Host-Country Contract is not G2G assistance, and the procedures and policies in this chapter does not cover it (see [ADS 301, Responsibility for Procurement](#) and [ADS 305, Host Country Contracting](#)).

### **220.3.6 Implementing through a Partner Government’s Systems and Institutions**

Effective Date: 01/13/2021

The implementation of a G2G activity starts upon signing of the G2G agreement. Figure 7 depicts and describes the implementation process.

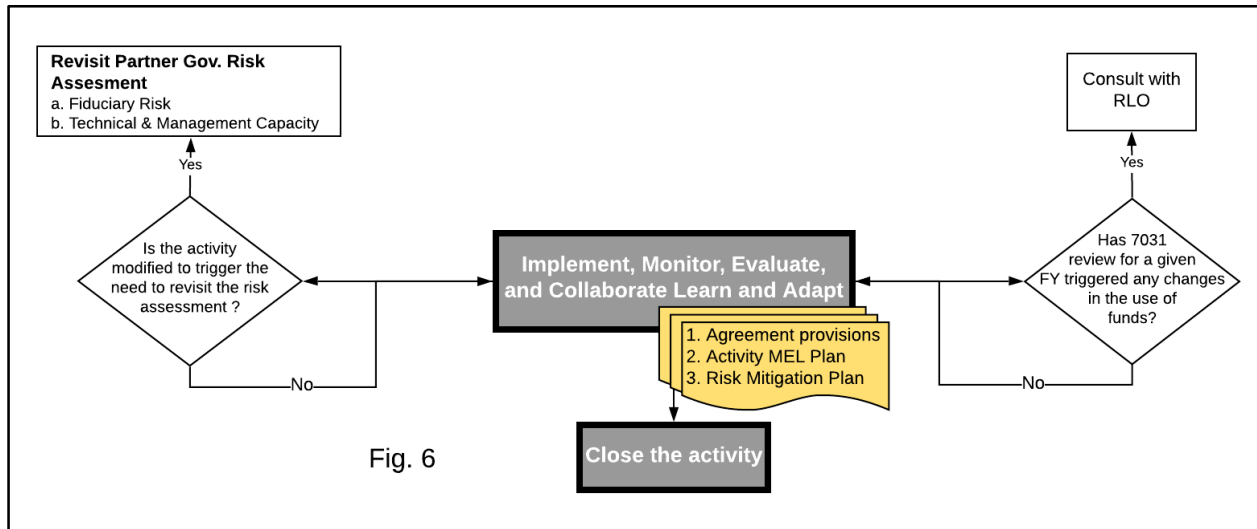

USAID and the partner government are mutually accountable for achieving the intended results of a G2G agreement. Both parties collaboratively manage implementation based on monitoring data, the findings of evaluations (if applicable), and contextual factors. A G2G agreement must define clear expectations about the activity's objectives; implementation plan; expected results; associated performance indicators to understand progress toward results; whether or not an evaluation will be conducted; and roles and responsibilities for who will collect and own performance and other activity data and commission any evaluations, resources, and timeline (see section **220.3.4.2**). Effective collaboration requires a common vision about how the activity and its outputs can lead to measurable higher-level results and a mutual understanding of programmatic and operational assumptions. Such active engagement by the partner government from the onset promotes local ownership of the development intervention and ultimately leads to a greater likelihood for the long-term sustainability of the desired outcomes through local funding.

Steps 6 and 7<sup>4</sup> of the Risk Management Process (see Figure 3 in **220.3.4**) are applicable to sections **220.3.6.2**, **220.3.6.3**, and **220.3.7**, with further details provided in the [G2G Risk Management and Implementation Guide](#).

- Step 6: Monitor and Review. After signing the agreement, and for the life of the G2G activity, the GATR and the PGST will monitor the risks identified in the RMP (see section **220.3.4.5**). Missions also have the option to engage or contract out risk mitigation and monitoring support through a third party technical assistance mechanism. Should additional risks develop, implementing teams should update the plan as necessary and develop additional measures to support risk monitoring, including the tracking of

<sup>4</sup> Note: Step 1 is the subject of **220.3.4.1** and **220.3.4.5** discusses Steps 2-5.

milestones in the G2G activity and triggers that can serve as an early signal of increasing risk exposures in implementation, or that may warrant the reconfirmation of risk mitigation strategies identified in the plan.

Similarly, the GATR should elevate severe or persistent risks identified and monitored over a G2G or programmatic portfolio for monitoring by the Mission's leadership, which could add them to the Mission's risk profile, if warranted. The key deliverable for this step is incorporating any risk monitoring into the RMP (see section **220.3.4.5**).

- Step 7: Communicate, Learn and Adapt <sup>5</sup>. GATRs play a key role in capturing the progress of G2G activities, making recommendations, and chronicling best practices. Knowledge management should be an iterative process throughout implementation to further inform activity design teams on promising practices and necessary pivots to support increased performance of current and future G2G programming (see [Incorporating CLA in the Management of Activities](#)). Missions should share best practices, tools, resources, and products in designing and managing G2G activities across the Agency via the [G2G Resource Library](#) on ProgramNet and with external stakeholders, as part of their CLA activities (see section **220.6.4**).

#### **220.3.6.1 Role and Designation of the Government Agreement Technical Representative (GATR)**

Effective Date: 01/13/2021

The Mission Director names a GATR for each G2G activity by using the GATR designation letter (see the [GATR Designation Letter Template](#)), which authorizes that person to provide oversight of the activity and any associated agreement(s) with the partner government implementing entity.

The GATR leads the multidisciplinary PGST team at the Mission to ensure that USAID exercises adequate management control over our assistance funds, and provides the necessary technical leadership, capacity-development and mentoring needed to achieve results. The PGST supports the GATR to manage the agreement, oversee implementation, and provide needed capacity-development assistance.

#### **Roles and Responsibilities of the GATR**

The GATR is the primary manager for a G2G activity. The role is similar to an Agreement Officer's Representative (AOR) for an assistance award or a Contracting Officer's Representative (COR) for an acquisition award, with some important differences, given the partnership nature of a G2G agreement. The GATR is the primary liaison between a Mission and a partner government on all matters related to

---

<sup>5</sup> This Step 7 should not be confused with the Collaborating, Learning and Adapting (CLA) Framework. In this context, it applies to communicating, learning, and adapting to the risks associated with G2G assistance.

the management and implementation of a G2G agreement. The GATR provides technical and administrative oversight of the agreement; ensures the prudent management of USAID's funds to achieve intended results; and establishes and maintains proper reporting, agreement files, and other documentation, including by uploading them into [ASIST](#). The GATR Designation Letter defines the specific roles and responsibilities of the GATR (see the [GATR Designation Letter Template](#)).

The GATR must demonstrate he or she has the right skill set for the role by having an active AOR/COR certification and maintaining it for the period of the G2G agreement (see [ADS 302](#), [ADS 303](#), and [ADS 458](#)).

### **Limitations of Authority, Standard of Conduct, and Conflicts of Interest**

As USAID employees, GATRs are subject to the same ethical standards that apply to all Federal employees by virtue of the terms of their employment. Being a GATR does not impose a higher standard for an individual's conduct, but G2G assistance could provide more occasions for improper behavior that increases scrutiny. Every GATR is responsible for protecting USAID's interests, and supporting its reputation for fair and equal dealings with all parties. Any potential (or appearance) of financial conflict of interest must be immediately reported to the appropriate parties to preserve public confidence in U.S. Government employees and the way we conduct business.

The GATR Designation Letter specifies that although a GATR has broad responsibility for the oversight of a G2G agreement, there are strict limitations on a GATR's authority. Generally, a GATR cannot change any of the terms of a G2G agreement, and under no circumstances can a GATR bind USAID to the commitment, obligation, or expenditure of funds not documented in the G2G agreement.

A GATR could be subject to disciplinary action for unauthorized acts or improper actions, in particular those related to agreement authority and financial management. In administering G2G agreements, improper actions include, but are not limited to, taking actions that are beyond the authority delegated in the GATR Designation Letter. A GATR should contact the RLO should questions arise on actions to take. In financial management, USAID's risk increases when GATRs act in a manner that is other than what would be expected of a reasonable individual. At a minimum, GATRs are expected to do the following:

- Take reasonable steps to ensure that the partner government implementing entity or entities has/have submitted all required agreement deliverables, services, and reports;
- Document and provide justification for the action, including determining if the partner government implementing entity has completed all necessary requirements before authorizing payment (the documentation, whether formal or not, should be easily understandable by an auditor or other third-party individual who reviews it); and

- Discuss with the PGST, Office Director, and RLO, and notify the Regional Inspector General if misuse or fraud related to use of USG resources is suspected.

A GATR should coordinate and work closely with the financial specialist on the PGST to ensure compliance with USAID’s financial-management requirements (see the [GATR Designation Letter Template](#)).

### **220.3.6.2 Planning for Monitoring, Evaluation, and CLA**

Effective Date: 01/13/2021

This chapter governs the planning for monitoring, evaluation, and CLA of a G2G agreement, based on principles and standards articulated in [ADS 201](#). [ADS 201](#) spells out general requirements for monitoring, evaluation and CLA, and [ADS 220](#) provides requirements specific to G2G agreements, including some special planning and implementation procedures, such as the requirement for an RMP. To ensure the integration of risk mitigation measures into the design, implementation, and monitoring of a G2G activity, the Mission should develop the RMP in tandem with the activity’s MEL Plan; see section [220.3.4.5](#) for more details. Also, Section 7031(a) of the SFOAA requires “effective monitoring and evaluation systems are in place to ensure that such assistance is used for its intended purposes.” In addition, the PGST team may include a Mission POC for MEL to support the GATR, who will interact with the POCs at the relevant Regional and Technical Bureaus, and with PPL, to ensure compliance.

All G2G activities must have an Activity MEL Plan, which specifies the procedures and processes to determine jointly with the partner government if the activity is on the right track and achieving expected results, and to course correct as needed based on new learning or contextual shifts. This requires up-front agreement during the design process, a collaborative approach, and joint decision-making in all phases of planning, implementing, and evaluating G2G activities.

The co-development of the Activity MEL Plan should start during the design phase; see section [220.3.4.5](#). Shared learning and joint ownership of the MEL Plan is critical so that all partners benefit from the investment in redefining USAID’s relationship with the partner government. The G2G Activity MEL Plan is, therefore, envisioned to be flexible to meet the needs of USAID and the partner government while promoting effective program management and adaptation, shared learning, and joint accountability.

**G2G Activity MEL Plan:** The G2G Activity MEL Plan reinforces equal partnership between USAID and the partner government by supporting local ownership, recognizing and leveraging existing host country MEL capacity, and strengthening MEL capacity in mutually agreed areas as relevant to programmatic success. USAID and the partner government are mutually accountable for achieving the intended results of the G2G agreement. Both parties, and possibly one or more third parties, will carry out the MEL responsibilities described in the Activity MEL Plan, with roles and duties clearly defined during the design phase. The assignment of these responsibilities will depend on a

variety of factors, such as contextual factors, analysis of risks, data needs, data-collection methods, MEL capacity of the partner government, or other requirements. Collaboration around the development of the Activity MEL Plan can be an opportunity to articulate a shared vision about how the activity and its outputs should lead to higher-level results supported by a common understanding of programmatic assumptions and risks, and mutual agreement on the steps needed to mitigate them.

A major difference between a G2G Activity MEL Plan and other types of implementing mechanisms is that USAID and the partner government will play a role in deciding and implementing the MEL Plan's tasks and approaches (and/or contracting with a third-party to do so), whereas in acquisition and assistance awards, the implementing partner is proposing a MEL plan that USAID approves.

Given the co-creation and co-design nature of the G2G assistance defined in this chapter, the actual negotiation and co-design efforts in many instances represents development results in their own right, rather than a primarily behind-the-scenes action that leads to a decision. Equally important as a valid development result is co-managing and co-monitoring of these activities in promoting adaptive management and agility of the very systems and institutions we are trying to strengthen.

To ensure that monitoring, evaluation and CLA support the mutual respect, shared contribution, and joint accountability necessary for an effective G2G partnership, the G2G Activity MEL Plan must do the following:

- Align with the partner government's strategic development plans and strategies, protocols, and guidance for monitoring and evaluation; this process already should have started during the design phase;
- Build on the activity's Theory of Change, and associated gaps in knowledge and assumptions, which guide decisions on priorities for monitoring, evaluation, and CLA;
- Identify whether any key risks in the risk-mitigation plan will require any programmatic monitoring efforts that should be part of the G2G Activity MEL Plan;
- Be practical and reflect a joint assessment and understanding of the partner government's existing systems and institutions and capacity in the sector the activity will be addressing;
- Define clear joint expectations and document agreement in the IL about the performance-management of the activity on the following:
  - Expected results, associated performance indicators, and other quantitative and qualitative measures of programmatic success;



- Data-quality standards and the methods for assessing the quality and integrity of data;
- Frequency and procedures for joint implementation reviews in which USAID and the partner government will assess progress toward achieving results, integrate learning to adapt and improve the activity, and troubleshoot constraints and problems;
- Whether an evaluation is planned, and if so, any details known on the type of evaluation and potential questions it will answer; and
- The roles and responsibilities of USAID, the partner government, and any third parties for monitoring, evaluation, and CLA, including for sustaining critical performance monitoring, continuous learning and improvement, and public accountability functions after the agreement ends.

Data-Management Plans (DMPs): As a complement to Activity MEL Plans, DMPs are required to identify data assets that the activity will create and use. DMPs are tools that guide the identification of anticipated data assets during the co-planning and co-design phase of G2G agreements and include the outlining and assigning of specific tasks needed to manage these assets across a full data lifecycle. Clear understanding of the ownership, sharing, and use rights of the data, and a timeline for delivering data assets to USAID and/or to the host government, should be part of the DMP. This ensures the use of best practices in data management and that data assets contribute to the Agency's evidence base. Missions should tailor DMPs for G2G activities to their overall scope, size, and purpose and their resulting data assets. A Mission may create and approve a DMP as a section of the MEL Plan, or as a separate plan. Similar to the Activity MEL Plan, OUs and Missions must put an Activity DMP in place before major implementation actions begin, upload it into [ASIST](#), and update it as necessary (see [ADS Chapter 579, USAID Development Data](#)).

### **220.3.6.3 Monitoring, Evaluation, and CLA During Implementation of a G2G Agreement**

Effective Date: 01/13/2021

#### **1. Monitoring**

As defined in [ADS 201](#), "monitoring" is the ongoing and systematic tracking of data or information relevant to the design and implementation of USAID's strategies, projects, and activities. OUs should analyze monitoring data for ongoing learning and to inform their efforts to manage adaptively and promote accountability, including evaluations.

G2G Activity MEL Plans should include a monitoring plan with performance indicators identified to track a limited number of key activity outcomes, as determined by USAID and the partner government. Achievement of milestones noted in a G2G agreement that can trigger a payment are not a substitute for the monitoring of key programmatic outcomes as part of the G2G Activity MEL Plan. The oversight of milestones, such as

work plan developed, technical assistance and training provided, and other immediate and tangible results, is important for managing an award, but does not fulfill the requirement for programmatic performance-monitoring of key outcomes identified in a G2G Activity MEL Plan.

If a partner government has an existing management information system it uses to collect, analyze, store and/or manage monitoring data, USAID should use that system, if applicable, rather than create new, duplicative information systems and institutions specific to the G2G agreement. In addition, Missions should track data on key performance indicators in their information management system. Missions must establish clear agreements and expectations with partner governments for the submission of data to USAID, including to the enterprise-wide Development Information Solution once available.

As defined in [ADS 201](#), Missions may use context indicators to track country/regional context; programmatic assumptions and the risks of strategies, projects, and activities; and operational context. G2G Activity MEL Plans should address plans for monitoring context and new or emerging programmatic and other risks that could affect the achievement of the activity's results and should document any planned decision points for the adaptation of programming and operations to address them. This supports consistency of risk responses with the Agency's [Risk Appetite Statement](#) and can feed into the reporting of prioritized risks and risk actions/treatments as part of our annual ERM exercise to update Risk Profiles at the OU and corporate levels.

Monitoring should be an inclusive process that includes Mission leadership, the PGST, other program and operations staff, the partner government, and other external stakeholders. The active engagement of external stakeholders helps identify how risks may affect different stakeholders and enables the OU to respond appropriately (see [Monitoring and Evaluation for a G2G Agreement](#)).

## **2. Information on Performance Indicators and Data-Quality Standards**

According to [ADS 201.3.5.7.D](#), Missions must document in a Performance Indicator Reference Sheet (PIRS) reference information on all performance indicators included in a G2G Activity MEL Plan. This information must be complete and sufficient within three months of the initial collection of the data. [ADS 201maf, Performance Indicator Reference Sheet \(PIRS\) Guidance & Template](#), describes the required indicator reference information for performance indicators.

As relevant, Missions should source indicators from pre-existing government-owned data, but they can create custom indicators for specific interventions. USAID and the partner government should work together to develop the PIRS for any indicators, and to establish clear terms for the sharing and use of these data, including indicators adopted from existing partner government performance monitoring systems.

Data on performance indicators should reasonably meet USAID's data quality standards, as defined in [ADS 201.3.5.8](#).

USAID and the partner government should determine jointly the procedures for conducting data quality assessments (DQAs). OUs must conduct a DQA for each performance indicator reported to external entities. This includes all indicators reported in the PPR or other external reporting. The DQA must occur after the collection of data on a new indicator and within 12 months prior to reporting the new indicator data. An OU must conduct a DQA every three years thereafter.

For performance indicators not reported to an external entity, USAID and the partner government should determine, at regular intervals, how to assess the quality of data either by using and strengthening existing host government procedures for the quality assurance of data, or, where necessary, by adapting USAID's Data Quality Assessment (DQA) process. OUs can build providing technical support and strengthening the capacity of a partner government to monitor programmatic performance into a G2G agreement to support national self-reliance and mitigate the immediate risks of using government-owned data and systems, increase local ownership, and support sustainability.

### **3. Evaluation**

The G2G Activity MEL Plan documents if, when, and how USAID and the partner government will conduct an evaluation of the G2G activity. As defined in [ADS 201](#), "evaluation" is the systematic collection and analysis of information about the characteristics and outcomes of strategies, projects, and activities conducted as a basis for judgments to improve effectiveness and timed to inform decisions about current and future programming.

The principles, standards, and requirements for evaluations outlined in [ADS 201.3.6](#) apply to G2G agreements, unless an OU makes an exception documented in a memorandum signed by the Mission Director or head of the Washington Bureau/Independent Office that outlines the reason for the exception. OUs must share copies of approved exception memoranda with PPL; Missions must share them with the MEL POC of the relevant Regional Bureau. CORs/AORs/GATRs must upload copies of such memoranda into [ASIST](#).

USAID requires evaluations for any activity, including G2G agreements, with an anticipated Total Estimated Amount/Total Estimated Cost of \$20 million or more. Missions may choose to evaluate other G2G agreements that do not meet this threshold as needed for accountability or learning purposes. If an evaluation is required, OUs should plan for that evaluation during the design of the G2G agreement and ensure it includes reference to the planned evaluation. One evaluation may cover multiple G2G agreements if they are all working towards the same result. Missions should use [ADS 201](#)'s evaluation requirement 1, "Each OU or Mission with a CDCS, RDCS or other strategy must conduct at least one evaluation per intermediate result (IR) defined in the OU's strategy. This evaluation can focus on any level within the IR: intervention, activity, set of activities, or the intermediate result as a whole." The G2G Activity MEL Plan should provide more details on planned evaluations, as described in [ADS 201](#).

USAID’s evaluation principles and standards recommend orienting evaluations toward reinforcing local ownership and national self-reliance ([ADS 201.3.6.2](#)). For G2G activities, OUs should conduct evaluations in a manner consistent with institutional aims of local ownership and engage respectfully with partners, including local beneficiaries and stakeholders, while leveraging and strengthening local evaluation capacity. The steps for evaluating G2G activities appear in [Monitoring and Evaluation for a G2G Agreement](#).

For G2G assistance, Missions should encourage partner governments to lead or co-lead, and fund evaluations in addition to any required USAID-funded evaluations. For evaluations funded by others, OUs should share USAID’s standards and requirements for the public disclosure of evaluations as the starting point for discussion during the activity design phase, to negotiate and document the right balance in the G2G agreement and subsequent Activity MEL Plan. When considering whether to evaluate, and planning for the evaluation of an activity implemented through a G2G agreement, USAID Missions should do the following:

- Determine if the policies of USAID or the partner government require an evaluation, or if the activity being implemented should undergo an evaluation even if not required;
- Establish the timing, focus, type, and intended use(s) of the evaluation, in collaboration with the partner government, and document these plans in the G2G Activity MEL Plan;
- Consider opportunities for a joint evaluation by USAID and the partner government, to understand and address challenges to implementation, revisit and revise the activity’s Theory of Change, or to inform future plans;
- Co-develop and prioritize jointly evaluation questions together with partner government counterparts, even if USAID and the partner government are not implementing the evaluation jointly, to ensure the evaluation is useful to the partner government as well as to USAID, to promote the use of the evaluation’s findings for adaptive management by the implementing partner government entity, and to promote the use of the evaluation’s findings for sustainability planning by the partner government;
- Consider addressing questions related to local ownership and sustainability in the evaluation by including questions on the prioritization, resourcing, and implementation of the G2G activity by the partner government; whether the G2G activity process fostered local ownership of the development activity or intervention; and whether that, in turn, resulted in the enhanced sustainability of outcomes achieved (see [Monitoring and Evaluation for a G2G Agreement](#)); and

- Plan to collaborate with the partner government to ensure the integration in the design of the evaluation all important questions, resources, and priorities for the use and dissemination of the report.

Types of evaluation. USAID categorizes evaluations as impact or performance evaluations depending on the purpose, questions, and corresponding design. Refer to [ADS 201.3.5.12](#) for more information on the types of evaluation.

Dissemination of G2G evaluation. The G2G MEL Plan should include expectations and processes for sharing and disseminating data, including the dissemination of any planned evaluation reports and the resulting findings to USAID and partner government audiences. Missions should review guidance in [ADS 201 \(201.3.6.10, Evaluation Use\)](#) to understand the standard requirements for USAID-funded evaluations and exemptions to them; and [ADS 540](#) and [ADS 579](#) for requirements related to the submission of data and reports to USAID. OUs must upload evaluation reports (including slide decks, evaluation summary, learning brief) to the Development Clearinghouse ([DEC](#)) and submit the evaluation's data to the Development Data Library ([DDL](#)); see [ADS 201.3.6.9, Evaluation Reports](#). USAID has a presumption in favor of openness and requires our OUs to make public all evaluation reports and data unless they meet one of a few principled exemptions to public disclosure outlined in [ADS 201mae, Limitations to Disclosure and Exemptions to Public Dissemination of USAID Evaluation Reports](#), and [ADS 201sag, Action Memorandum Template for Exception to Public Disclosure of USAID-Funded Evaluation](#). Exemptions include “when the laws or regulations of a recipient country apply to a bilateral agreement and restrict access to information.”

USAID and the partner government should identify potentially sensitive data and information and consider reasonable steps to protect such information while sharing as broadly as possible. USAID can support local ownership through enhanced accountability, transparency, and inclusive learning by creating opportunities for partner governments, civil society, academia, the private sector, and citizens to engage in constructive dialogue around G2G activities, and through sharing data and evaluation findings.

#### **4. Collaborating, Learning, and Adapting (CLA)**

CLA is USAID's approach to organizational learning and adaptive management. Strategic collaboration, continuous learning, and adaptive management link together all components of the Program Cycle (see [Collaborating, Learning, and Adapting Framework and Key Concepts](#)).

G2G programming should use evidence to make adjustments as necessary to enhance the development results of the activity throughout implementation. USAID's staff should integrate CLA throughout the design and implementation of a G2G activity, model CLA practices, and encourage them in local partners, including by building in actions to strengthen the capacity of the partner government. CLA approaches lay the foundation for an open, trusting, and learning-oriented relationship with local partners, and facilitate

collaboration, learning, and adapting throughout the life of the activity to achieve development outcomes (see [CLA in Activity Design and Implementation](#)).

Planning for CLA ensures G2G activities are well-coordinated across USAID, partner governments and other actors, grounded in evidence, and adjusted as necessary to remain relevant throughout implementation. Both USAID and the partner government need to undertake joint CLA throughout the life cycle of a G2G activity, as agreed in the G2G Activity MEL Plan. G2G-appropriate CLA approaches include the following:

- Holding periodic meetings, joint assessments, and portfolio reviews with the partner government, potentially with other donors and stakeholders;
- Reflecting critically on the activity’s Theory of Change in collaboration with the partner government, to revisit assumptions and address unexpected or emergent factors that are creating or closing windows of opportunity;
- Updating analyses conducted during the design of the activity to reassess assumptions;
- Allocating staff time and resources from both USAID and the partner government to joint site visits, data exploration, and sense-making; and
- Making joint updates or adaptations to the design and/or management structures of the activity and processes to incorporate new knowledge and learning.

Sources of information that can inform learning and programmatic adaptation include performance monitoring data, portfolio reviews, research and analyses, evaluations, audits, and others. New findings and learning may prompt the Mission, the partner government, and other stakeholders to reassess jointly the implementation approach, outputs, and expected outcomes of the activity. Planning for CLA ensures G2G activities are well-coordinated across USAID, partner governments and other actors, grounded in evidence, and adjusted as necessary to remain relevant throughout implementation. Further information on the Agency’s CLA approach appears in [ADS 201.3.7](#). For specific lessons learned needed for closing out a G2G activity, see section [220.3.7](#).

#### **220.3.6.4 Managing the G2G Agreement and the Relationship with the Partner Government**

Effective Date: 01/13/2021

G2G agreements rely on a partner government’s processes and practices for implementation and includes the complementary objective of strengthening its capacity to achieve and sustain measurable development outcomes, while effectively managing U.S. taxpayer funds. This reliance on and strengthening of national and local systems and institutions and capacities can be effective when the relationship between USAID

and the partner country government is characterized by mutual respect, shared contribution, and joint accountability for results.

## **1. Managing the Agreement and Monitoring the Risk Mitigation Plan (RMP)**

Managing a G2G agreement includes the monitoring and oversight of additional aspects associated with the terms and conditions of such agreements. In addition to the G2G Activity MEL Plan, OUs must monitor an RMP throughout the life of a G2G activity.

All G2G activities must have and monitor an RMP, incorporated in the final agreement, which is key to tracking organizational capacity and contribution to achieving the objectives of the G2G activity.

To ensure OUs integrate risk mitigation measures into the design, implementation, and monitoring of a G2G activity, they should create the RMP in tandem with the Activity MEL Plan. The RMP must include the steps USAID and the partner government agree to take to mitigate risks identified through risk assessments, evaluations, or audits, and should include provisions to verify jointly the partner government's follow-up on any risk-mitigation measures identified. These could include specific indicators that track the partner government's compliance with risk mitigation measures, benchmarks to demonstrate progress in correcting its financial management weaknesses and agreed milestones.

The RMP should identify "risk owners," who are individuals responsible for specific actions to mitigate identified risks. Since internal and external risks are interrelated, risk owners can include USAID, the partner government, and other stakeholders. Risk owners, identified during the risk assessment process, are responsible for actions and regular updates as part of the G2G monitoring coordinated by the GATR, supported by the Mission MEL POC.

The monitoring of activity milestones is required, but is not sufficient, to understand progress toward an activity's intended outcomes. Milestones noted in a G2G agreement intended to trigger a payment are not a substitute for a G2G Activity MEL Plan. Monitoring for the oversight of outputs (*e.g.*, milestones, such as work plan developed, technical assistance and training provided, and other immediate and tangible results) is important and a required task, but does not fulfill the requirement for performance monitoring of outcomes identified in the activity's logic models (*e.g.*, new human resources practices adopted, service-delivery improved, and other higher-level objectives).

## **2. Triggers for Revisiting the Risk Assessment and G2G Assistance**

Risk indicators serve as triggers for revisiting the risk assessment, RMP, and Capacity Development Plan. New information about context, assumptions, risks, and causal relationships discovered through monitoring, audits, or from mid-course evaluations may require updating the activity's design or implementation approach based on a revised Theory of Change, or renegotiating modifications to the G2G agreement (see

the [G2G Risk Management and Implementation Guide](#)). Illustrative other factors that could trigger the revisiting of the risk assessment include the following:

- An increase in funding from USAID, or new or increased resources from the partner government or another donor;
- An extension of the activity's life;
- Support for partner government entities that implemented activities in the past and USAID is considering for new assistance;
- A change or addition of implementing mechanism;
- Consistent, unexplained slow progress in the activity;
- Dramatic host-country (national) political or constitutional changes;
- Significant changes in the USG's posture in or with the host country;
- A prolonged humanitarian disaster or crisis; and
- Significant limitations or scope introduced/placed on the partner government's accountability institutions (e.g., anti-corruption commission, supreme audit institution).

### **3. Managing the Relationship with the Partner Government (Key to Success)**

The GATR has a key role in managing a G2G agreement and the relationship with the partner government and serves as an interlocutor between the various Mission offices involved in the implementation of a G2G activity and the implementing institutions within the partner government. Managing USAID funds through partner governments could involve several government entities, such as the Ministry of Finance, Central Bank, and the implementing ministry or organization (e.g., local governments, etc.). In addition, even within USAID, challenges related to the implementation of an activity often involve several Mission staff in addition to the designated GATR. Thus, establishing successful relationships both externally and internally goes beyond formal communications and draws on a range of CLA approaches; see the [CLA Toolkit: Engaging Stakeholders](#). A strong relationship with the partner government involves ongoing engagement with its officials and implementing institutions. In a Mission, the GATR serves as the point person for ensuring that the Mission's staff remain engaged in the success of the activity. Missions should consider the following in establishing a partnership relationship with host governments:

- 1) Acknowledge the partnership nature of these agreements, which entails shared responsibility, accountability, and decision-making:



- a. Understand shared equities;
  - b. Align goals and objectives to achieve key results; and
  - c. Gain buy-in for initiatives and resolutions to promote accountability and collaboration.
- 2) Recognize the importance of establishing and maintaining a true partnership, which is key to effectively promoting commitment, ownership, and enhancing and financing self-reliance:
- a. Establish joint working groups:
 

It is often appropriate to establish one or more working groups that meet regularly over the life of the activity. Such working groups could include representatives from a variety of partner government entities with an interest in the activity. Depending on the nature and level of management cooperation involved, the IL may formally establish such groups. USAID's participants could include members of the PGST, as designated by the Mission Director, as well as non-governmental and other stakeholders, as appropriate;
  - b. Invite officials from the partner government to participate in periodic portfolio reviews and/or financial reviews;
  - c. Engage in decision-making on modifications to the activity;
  - d. Identify opportunities to strengthen the capacity of key partner government staff; and
  - e. Strengthen negotiation, coordination, and project management skills of both USAID's staff and officials from the partner government:
    - Make Mission resources available for GATRs to take relevant training in negotiation and project management skills (for example, soft skills such as critical thinking, active listening, effective communication, and facilitation).

### **220.3.7 Closing Out a G2G Activity**

Effective Date: 01/13/2021

Close-out is the final phase of an activity's lifecycle. This phase is of equal importance as the other three phases (planning, design, and implementation). Key staff members have important roles in the administrative close-out process of all activities at a USAID Mission, and they must coordinate until the signature of the award completion statement. Each role has specific tasks at different points in time.

## 1. Administrative Close-Out

The administrative close-out process for G2G agreements is no different from that of other USAID-funded instruments. The GATR should plan to initiate the G2G close-out process 90 days before the date of completion of the agreement. This close-out process should begin when obligated funds are either expended or identified for de-obligation, upon receipt of final claim and the satisfaction of the requirements (terms and conditions) of the G2G agreement.

The GATR has a key role in the close-out process for a G2G agreement:

- Notifies the partner government in writing that USAID is preparing to close out the agreement;
- Ensures the Mission has paid out final vouchers and liquidated all advance payments;
- Ensures the partner government has completed all terms of the agreement;
- Ensures the partner government has signed a release of all further claims;
- Updates the RMP and documents any risk measures that could not be completed (this will be important if there is a future agreement with the partner government); and
- Prepares the Close-out Memo for the file; see the [Template for G2G Close-Out](#).

Missions may develop internal procedures through Mission Orders that guide the close-out process (see [G2G Close-Out Checklist](#)).

## 2. Knowledge-Capture

[ADS 201.3.4.13](#) says: “As part of the close-out process, OUs should also consider how to capture and share the knowledge and learning gained during the implementation of an activity, including how to apply lessons learned to future projects or activities. OUs may document this information in a written final report, an evaluation, a conference/event, a video, or online materials, among other options. If produced by the implementing partner, OUs must ensure that the partner has planned and budgeted for these learning materials in advance, in accordance with the terms of their agreement.”

Missions should share documents that summarize lessons learned, results, and risk assessment and risk management approaches from G2G agreements with the Country Support Network designated through the [Agency Approach to Field Services](#).

Missions should share their learnings in the G2G Resource Library, an online repository of Mission-developed documents, tools, templates, process maps, training materials, and other resources for G2G assistance.

### 3. Records-Management

Missions must use [ASIST](#) as the central repository for all risk assessment reports, risk response plans, supporting documentation, agreements with partner governments, and closeout reports associated with G2G assistance (see the [Consolidated Audit and Compliance System \(CACs\)/Tracking Audit Consolidated System \(TRACS\) - Mission User Guide](#), a module within [ASIST](#)). This repository allows Missions to track assessments, as well as develop a uniformed audit inventory and audit plan. TRACS is linked to, and complements, Phoenix, the Global Acquisition and Assistance System (GLAAS), and CACS (see [Operation and Maintenance \(O&M\) of USAID's Information Technology Infrastructure and Systems Program](#)).

For assessments completed prior to October 1, 2018, Missions can determine if they retroactively update TRACS with historical risk assessment reports and supporting documentation, which could be useful to inform future assessments.

Missions must maintain documentation records, after the close-out date of the agreement, in accordance with [ADS 502](#), disposition schedule [ADS 502maa](#), and [ADS 511](#).

#### 220.4 MANDATORY REFERENCES

##### 220.4.1 External Mandatory References

Effective Date: 01/13/2021

- a. [Busan Partnership for Effective Development Cooperation](#)
- b. [Council of the Inspectors General on Integrity and Efficiency: Inspectors General Guide to Assessing ERM](#)
- c. [GAO: A Framework for Managing Fraud Risks in Federal Program](#)
- d. [GAO's Standards for Internal Control in the Federal Government](#)
- e. [OMB Circular A-11, Preparation, Submission and Execution of the Budget](#)
- f. [OMB Circular A-123, Management's Responsibility for risk-management and Internal Control](#)
- g. [Paris Declaration on Aid Effectiveness](#)
- h. [Playbook: Enterprise risk-management for the U.S. Federal Government](#)

**220.4.2 Internal Mandatory References**

Effective Date: 01/13/2021

- a. [ADS 201, Operational Policy for the Program Cycle](#)
- b. [ADS 201mai, Activity Approval Memo \(AAM\)](#)
- c. [ADS 220mac, Pre-Obligation Requirements for Government to Government \(G2G\) Assistance](#)
- d. [ADS 220mag, G2G Implementing and Funding Mechanisms Cost Reimbursement Projects](#)
- e. [ADS 220mah, G2G Implementing and Funding Mechanisms Fixed Amount Reimbursement](#)
- f. [ADS 220maj, Advances for Government to Government Assistance](#)
- g. [ADS 220mak, Process and Documentation Requirements for G2G Assistance](#)
- h. [ADS 220mal, G2G Activity Planning Approval Memo \(APAM\)](#)
- i. [ADS 302, USAID Direct Contracting](#)
- j. [ADS 303, Grants and Cooperative Agreements to Non-Governmental Organizations](#)
- k. [ADS 305, Host Country Contracts](#)
- l. [ADS 308, Agreements with Public International Organizations](#)
- m. [ADS 310, Source and Nationality Requirements for Procurement of Commodities and Services Financed by USAID](#)
- n. [ADS 350, Grants to Foreign Governments](#)
- o. [ADS 350mac, Development Objective Agreement and Bilateral Agreement Template \(non-health\)](#)
- p. [ADS 350mad, Development Objective Agreement and Bilateral Agreement Template \(health\)](#)
- q. [ADS 351, Agreements with Bilateral Donors](#)

- r. [ADS 579, USAID Development Data](#)
- s. [ADS 591, Financial Audits of USAID Contractors, Recipients, and Host Government Entities](#)
- t. [ADS 591maa, USAID Financial Audit Guide for Foreign Organizations](#)
- u. [ADS 596mab, Governance Charter for Enterprise Risk Management and Internal Control at USAID](#)
- v. [ADS 624, Host Country-Owned Foreign Currency](#)
- w. [Host Country Contracting](#)
- x. [USAID's Risk Appetite Statement](#)
- y. [Use of Fixed-Amount Reimbursement Method for Local-Cost Financing](#)

**220.5            ADDITIONAL HELP**

Effective Date: 01/13/2021

- a. [ADS 220sai, Sector Program Assistance \(SPA\) Agreement Template](#)
- b. [ADS 220saj, Balance of Payments/General Budget Support \(BoP-GBS\) Assistance Agreement Template](#)
- c. [ADS 220sak, Writing Framework](#)
- d. [Checklist for G2G Close-Out](#)
- e. [Compilation of Analyses and Assessments \(ADS 201 Additional Help\)](#)
- f. [Consolidated Audit and Compliance System \(CACs\)/Tracking Audit Consolidated System \(TRACS\) - Mission User Guide](#)
- g. [Cost Reimbursement Implementation Letter Template](#)
- h. [Counter-Trafficking in Persons Field Guide](#)
- i. [Counter-Trafficking in Persons Policy](#)
- j. [Expanded DRG Review Guidance](#)
- k. [Fixed Amount Reimbursement Implementation Letter Template](#)
- l. [GATR Designation Letter Template](#)

- m. [G2G Risk Management and Implementation Guide](#)
- n. [How-to-Note: Tailoring the Risk Assessment](#)
- o. [Local Systems: A Framework for Supporting Sustained Development](#)
- p. [Monitoring & Evaluation for a Government-to-Government Agreement \(ADS 201 Additional Help\)](#)
- q. [Program Cycle Discussion Note: Co-Creation Additional Help](#)
- a. [Program Cycle Technical Note: Enterprise Risk Management in the Program Cycle](#)
- b. [Template G2G Close Out: Checklist of Considerations for G2G Close-Out](#)
- c. [The Role of the DOAG and IL in Funding G2G Activities](#)
- d. [USAID Implementing Mechanism Matrix – ADS 201 Additional Help](#)

## 220.6 DEFINITIONS

Effective Date: 01/13/2021

See the [ADS Glossary](#) for all ADS terms and definitions.

### **Activity Approval Memorandum (AAM)**

A brief action memorandum that approves an activity design. AAMs may approve one design or multiple, complementary designs depending on the circumstances. An AAM is also used to approve the use of partner government systems in implementation of G2G assistance (formerly known as the Approval for the Use of Partner Government Systems (AUPGS)). (**Chapter 201** and **220**)

### **Activity Planning Approval Memorandum (APAM)**

A brief action memorandum that confirms eligibility, establishes viability, and approves the planning parameters that will guide the design for a G2G activity. APAMs may approve one design or multiple, complementary designs depending on the circumstances. (**Chapter 220**)

### **Capacity**

The ability of a human system to perform, sustain itself, and self-renew, that is, the ability of people, organizations, and society to manage their affairs successfully. Capacity encompasses the knowledge, skills, and motivations, as well as the relationships, that enable an actor—an individual, an organization, or a network—to design and take action to implement solutions to local development challenges, to learn and adapt from that action, and innovate and transform over time. Capacity of any one

actor is highly dependent upon its fit within the context of a local system and institutions and the enabling environment. (**Chapter 220**)

### **Capacity-Development**

The process of unleashing, strengthening, and maintaining such capacity. Capacity is a form of potential; it is not visible until it is used. Therefore, performance is the key consideration in determining whether capacity has changed. Organizations with improved performance will have undergone a deliberate process undertaken to improve execution of organizational mandates to deliver results for the stakeholders it seeks to serve. (See [Standard Foreign Assistance Indicator CBLD-9 Capacity-Building](#)) (**Chapter 220**)

### **Compliance Risk**

The risk of failing to comply with applicable laws and regulations, and the risk of failing to detect and report activities that are not compliant with statutory, regulatory, or organizational requirements. A lack of awareness or ignorance of the pertinence of applicable statutes and regulations to operations and practices can cause compliance risk. (See [Playbook: ERM in the U.S. Federal Government](#)) (**Chapter 220**)

### **Context**

Conditions and external factors relevant to implementation of USAID strategies, projects, and activities. Context includes the environmental, economic, social, or political factors that may affect implementation, as well as how local actors, their relationships, and the incentives that guide them affect development results. It also includes risks that may threaten or provide opportunities to achieve greater development impact. (**Chapter [201](#) and 220**)

### **Context Indicator**

A means to monitor factors outside the control of USAID that have the potential to affect the achievement of expected results. Context indicators may be tracked at any level of a Results Framework or logic model. Context indicators may be used to track country/regional context; programmatic assumptions of strategies, projects, and activities; and operational context. Context indicators do not directly measure the results of USAID activities. (**Chapter [201](#) and 220**)

### **Context Monitoring**

The systematic collection of information about conditions and external factors relevant to the implementation and performance of an OU's strategy, projects, and activities. Context monitoring includes the monitoring of local conditions that may directly affect implementation and performance (such as non-USAID programming operating within the same sector as USAID programming) or external factors that may indirectly affect implementation and performance (such as macro-economic, social, or political conditions). It also includes monitoring risks such as programmatic, fiduciary, reputational, legal, security, human capital, and information technology. (**Chapter [201](#) and 220**)

**Contextual Risk**

The range of potential adverse outcomes that could arise in a particular context, such as the risk of political destabilization, a return to violent conflict, economic deterioration, natural disaster, humanitarian crisis, or cross-border tensions. Development agencies only have a limited influence on contextual risk in the short term, but they seek to fund interventions that create conditions for reduced contextual risk in the long term, for example by promoting state-building and peace-building processes, strengthening the management of disaster risk, and promoting economic reforms that increase resilience in the face of shocks. (See [Development Assistance Committee of the Organization for Economic Co-operation and Development](#)) (Chapter 220)

**Enterprise Risk-Management (ERM)**

An Agency-wide approach to addressing the full spectrum of the organization's external and internal risks by understanding the combined impact of risks as an interrelated portfolio, rather than addressing risks only within silos. (Chapters [201](#), [220](#), [596mab](#))

**Fiduciary Risks**

Events or circumstances that could result in fraud, waste, loss, or the unauthorized use of U.S. Government funds, property, or other assets. It also refers to conflicts of interest that could have an adverse effect on the accountability of U.S. taxpayer dollars, or the realization of development or humanitarian outcomes. (Chapter 220)

**Financial Risk**

Risk that could result in a negative impact to the Agency (waste or loss of funds/assets). (See [Playbook: ERM in the U.S. Federal Government](#).) (Chapter 220)

**Fraud**

Dishonesty in the form of an intentional deception or a willful misrepresentation of a material fact. (Chapter 220)

**Government Agreement Technical Representative (GATR)**

An individual typically designated by a Mission Director as part of the administration of partner government agreements. The GATR, like an AOR or COR for A&A awards, has a formal designation letter or memorandum from the Mission Director defining his/her roles, responsibilities, and authorities. (Chapter [201](#) and [220](#))

**Human-Capital Risks**

Events or circumstances that could improve or compromise the capacity, productivity, hiring, or retention of employees. (See [USAID's Risk-Appetite Statement](#)) (Chapter 220)

**Impact**

The positive or negative effect of an event on strategic goals and objectives. (See [Playbook: ERM in the U.S. Federal Government](#)) (Chapter 220)

**Implementation Letter**



Formal correspondence between USAID and another party following a formal agreement that obligates funding. Implementation letters serve several functions, including providing more detailed implementation procedures, providing details on terms of an agreement, recording the completion of conditions precedent to disbursements, and approving funding commitments and mutually agreed-upon modifications to program descriptions. (**Chapter [201](#)** and **220**)

### **Information Technology (IT) Risks**

Events or circumstances that could potentially improve or compromise the processing, security, stability, capacity, performance, or resilience of IT. (See [USAID's Risk Appetite Statement](#)) (**Chapter 220**)

### **Inherent Risk**

The exposure arising from a specific risk before any action has been taken to manage it beyond normal operations; often referred to as “the risk of doing business.” (See [Playbook: ERM in the U.S. Federal Government](#)) (**Chapter 220**)

### **Key Risk Indicator (KRI)**

Indicators that relate to a specific risk and demonstrate a change in the likelihood or impact of the risk event. (See [Playbook: ERM in the U.S. Federal Government](#)) (**Chapter 220**)

### **Legal Risks**

Events or circumstances that potentially could improve or compromise compliance with law, regulation, Executive Order, or other source of legal requirement. (See [USAID's Risk-Appetite Statement](#)) (**Chapter 220**)

### **Likelihood**

The probability that a given event will occur. (See [Playbook: ERM in the U.S. Federal Government](#)) (**Chapter 220**)

### **Local Capacity-Development**

An investment into improving the performance of local actors—individuals, organizations, and networks—to produce jointly valued development outcomes. Effective local capacity-development strategically and intentionally supports an actor's ability to achieve its own mission, to learn, and adapt to remain relevant to changing context, and to innovate and transform to sustain development outcomes over time. (**Chapter 220**)

### **Local Ownership**

The commitment and ability of local actors—including the governments, civil society, the private sector, universities, individual citizens, and others—to prioritize, resource, and implement development, so that development outcomes have a greater potential to be sustained and generate lasting change without USAID assistance. (**Chapter [201](#)** and **220**)

**Local System**

The interconnected set of actors—inclusive of individuals, organizations, and networks representing government, civil society, the private sector, universities and research institutes, and others—that jointly produce a particular humanitarian or development outcome. As a set of interconnected actors jointly produce an outcome, they are “local” to it. Thus “local” in a local system refers to all relevant actors in a partner country. Local systems may reflect or cut across sub-national, national, or regional geographies. (Chapter 220)

**Monitoring**

The ongoing and systematic tracking of data or information relevant to USAID policies, operations, programs, strategies, projects, and activities. Relevant data and informational needs are identified during planning and design and may include output and outcome measures that are directly attributable to or affected by USAID interventions, as well as measures of the operating context and programmatic assumptions. (Chapter [201](#) and 220)

**Operational Risk**

The risk of direct or indirect loss from inadequate or failed internal processes, people, systems, institutions, or external events. It can cause financial or reputational loss, or the loss of competitive position or regulatory sanctions. (See [Playbook: ERM in the U.S. Federal Government](#)) (Chapter 220)

**Opportunity**

A favorable or positive event. In the context of risk-management, it refers to the possibility that an event will occur and positively affect the achievement of objectives. (See [Playbook: Enterprise Risk-Management for the U.S. Federal Government](#)) (Chapter 220)

**Partner Government Implementing Entity**

An office, organization, or body at any level of a public administration system (ministry, department, agency, service, district, or municipality) in a partner country that implements activities financed by or jointly programmed as a result of funds disbursed by USAID directly to the partner government’s public financial-management system. (Chapter 220)

**Performance Indicators**

The measures USAID uses to detect progress toward the results included in a Results Framework. When it pairs each result with appropriate and precise measures, USAID eliminates a good deal of the ambiguity that is inherent in many results statements. (See [USAID Project Starter](#)) (Chapter 220)

**Performance Management**

The systematic process of planning and defining a Theory of Change and associated results through strategic planning and program design, and collecting, analyzing, and using information and data from program-monitoring, evaluations, and other learning

activities to address learning priorities, understand progress toward results, influence decision-making and adaptive management, and ultimately improve development outcomes. Each USAID Mission's Performance-Management Plan describes performance-management activities at the Mission level. Performance-management supports continuous learning and adaptive management. (**Chapter [201](#) and [220](#)**)

### **Performance Management Plan (PMP)**

A Mission-wide tool to plan and manage the process of identifying and addressing strategic learning priorities through monitoring, evaluation, and CLA activities and approaches, including by validating Theories of Change; monitoring progress and performance; tracking programmatic assumptions and changes in operational context; evaluating performance and impact; and using other learning activities to convene key stakeholders to learn from evidence, inform decision-making, the allocation of resources, and adaptation at the strategy level. PMPs are Mission documents and are distinct from Activity MEL Plans. (**Chapter [201](#) and [220](#)**)

### **Performance Monitoring**

The ongoing and systematic collection throughout strategies, projects, and activities of performance-indicator data and other quantitative or qualitative information to reveal whether implementation is on track and whether expected results are being achieved. Performance-monitoring includes monitoring the quantity, quality, and timeliness of activity outputs within the control of USAID or its implementers, as well as the monitoring of project and strategic outcomes expected to result from the combination of these outputs and other factors. (**Chapter [201](#) and [220](#)**)

### **Performance Plan and Report (PPR)**

The PPR documents U.S. Government foreign assistance results achieved over the past fiscal year and sets targets on designated performance indicators for the next two fiscal years. (**Chapter [201](#) and [220](#)**)

### **Probability**

A quantitative measure that indicates the possibility that a given (risk) event will occur, usually expressed in terms of a percentage, frequency of occurrence, or other numerical metric. (**[Adapted from Playbook: ERM in the U.S. Federal Government](#)**) (**Chapter [220](#)**)

### **Program**

Within the context of the Program Cycle, "program" usually refers to either a Mission's entire portfolio, or to an entire technical sector portfolio, under a CDCS. For Washington Operating Units and other Operating Units that do not have a CDCS, "program" generally refers to a set of projects or activities that support a higher-level objective or goal. (**Chapter [201](#) and [220](#)**)

### **Program Assistance or Non-Project Assistance (used interchangeably)**

A generalized resource transfer, in the form of foreign exchange or commodities, to a partner government to alleviate policy- or resource-based constraints. Individual

transfers or disbursements of funds depend on the completion, by the partner government, of the mutually defined and agreed-upon performance benchmarks. This contrasts with other types of assistance in which USAID finances specific inputs, such as technical assistance, training, equipment, vehicles, or capital construction. (**Chapter 220**)

### **Programmatic Risks**

Events or circumstances that potentially could improve or undermine the effectiveness of USAID's development or humanitarian assistance. (See [USAID's Risk Appetite Statement](#)) (**Chapter 220**)

### **Project**

A group of activities designed and managed in a coordinated way to advance result(s) set forth in a CDCS (or other strategic framework) and foster lasting gains along the Journey to Self-Reliance in a country or region. Through a project approach, Missions and other Operating Units can create synergies among complementary activities that generate higher-level results achievable through the sum of their individual performances. (**Chapter 201** and **220**)

### **Readiness to Partner**

The ability of an organization to enter a formal contractual relationship with USAID or one of its lead implementing partners. It requires that an organization have sufficiently robust financial controls and management systems and institutions to minimize or eliminate the likelihood that risk will occur for USAID because of entering into such a partnership. (**Chapter 220**)

### **Reporting Risk**

The risk associated with the accuracy and timeliness of information needed within an organization to support decision-making and performance-evaluation, as well as outside the organization to meet standards, regulations, and stakeholder expectations; a subset of Operational Risk. (See [Playbook: ERM in the U.S. Federal Government](#)) (**Chapter 220**)

### **Reputational Risks**

Events or circumstances that potentially could improve or compromise USAID's standing or credibility with Congress, the interagency, the American public, host-country governments, multilateral institutions, implementing partners, beneficiaries, or other stakeholders. (See [USAID Risk-Appetite Statement](#)) (**Chapter 220**)

### **Risk**

The effect of uncertainty on objectives (see [ADS 596mab](#)). Within USAID's Program Cycle, a risk refers to an uncertain event or circumstance that, if it occurred, would hinder the Operating Unit's ability to achieve intended results. (**Chapter 201** and **220**)

### **Risk Appetite**

The broad-based amount of risk an organization is willing to accept in pursuit of its mission/vision. (**Chapters [201](#), [220](#), [596mab](#)**)

### **Risk Assessment**

The identification and analysis of risks to the achievement of strategic, program, and operational objectives, which forms a basis for determining how an organization should manage such risks. Risk-assessment involves estimating the significance and likelihood of a risk, as well as any controls or other measures that mitigate or eliminate it. (**Chapters [201](#), [220](#), [596mab](#)**)

### **Risk Impact**

A measurement of the effect that could result from the occurrence of a particular identified risk. (See [Playbook: ERM for the U.S. Federal Government](#)) (**Chapter [220](#)**)

### **Risk Management**

A coordinated activity to direct and control challenges or threats to achieving an organization's goals and objectives. (See [Playbook: ERM for the U.S. Federal Government](#)) (**Chapter [220](#)**)

### **Risk Mitigation**

A strategy for managing risk that seeks to lower or reduce the significance and/or likelihood of a given risk. (See [Playbook: ERM for the U.S. Federal Government](#)) (**Chapter [220](#)**)

### **Risk Profile**

A document that provides a thoughtful analysis of the significant risks an organization faces to achieving its strategic objectives that arise from its activities and operations, and appropriate options for addressing them. (**Chapters [201](#), [220](#), [596mab](#)**)

### **Risk Response (or Strategy)**

A strategy for managing (or responding to) a given risk. Risk-response strategies include avoidance, sharing, reduction, transfer, and acceptance. (See [Playbook: ERM for the U.S. Federal Government](#)) (**Chapter [220](#)**)

### **Risk Tolerance**

The acceptable level of variance in performance relative to the achievement of objectives, with special consideration to the relative importance of related objectives. Risk tolerance must align with risk appetite. (**Chapters [201](#), [220](#), [596mab](#)**)

### **Security Risks**

Events or circumstances that potentially improve or compromise the security of USAID's staff, partners, property, information, funding, or facilities. (See [USAID's Risk-Appetite Statement](#)) (**Chapter [220](#)**)

### **Self-Reliance**

A country's capacity to plan, finance, and implement solutions to local development challenges, as well as its commitment to see these through effectively, inclusively, and with accountability. (**Chapter [201](#)** and **220**)

**Strategic Risk**

Risk that would prevent the accomplishment of objectives (meeting the mission). (**[Adapted from Playbook: ERM in the U.S. Federal Government](#)**) (**Chapter 220**)

**Trigger**

A value or threshold that, if crossed, would prompt an action, such as re-examination of a Results Framework or logic model. (See **[Program Cycle Monitoring Toolkit: Context Indicator Reference Sheet \(CIRS\) Template](#)**) (**Chapter 220**)

**Uncertainty**

The inability to know in advance the exact likelihood or impact of future events. (See **[Playbook: ERM in the U.S. Federal Government](#)**) (**Chapter 220**)

220\_011521